

MACHINE SHIELDS

Safety Scales, Safety Signs, and Lamps



Bench Grinder Safety Scale, page 5



Guard Safety Scales, pages 2-3



Steel Lathe Chuck Shields, pages 18-23



Lathe Chuck and Carriage Shields, pages 16-25



Roller Shields, pages 14-15



Snake-Arm Shields, pages 30-35

**Special Shields and Guards • Machine Safety Surveys
Machine Safety Training • Safeguard Installation • OSHA Compliance Assistance**

SHOP ONLINE AT WWW.DANRAYPRODUCTS.COM

Toll-Free 1.866.482.6807 / Phone 815.262.6667 / Fax 815.282.5186

Catalog MS

OSHA Guard Safety Scale

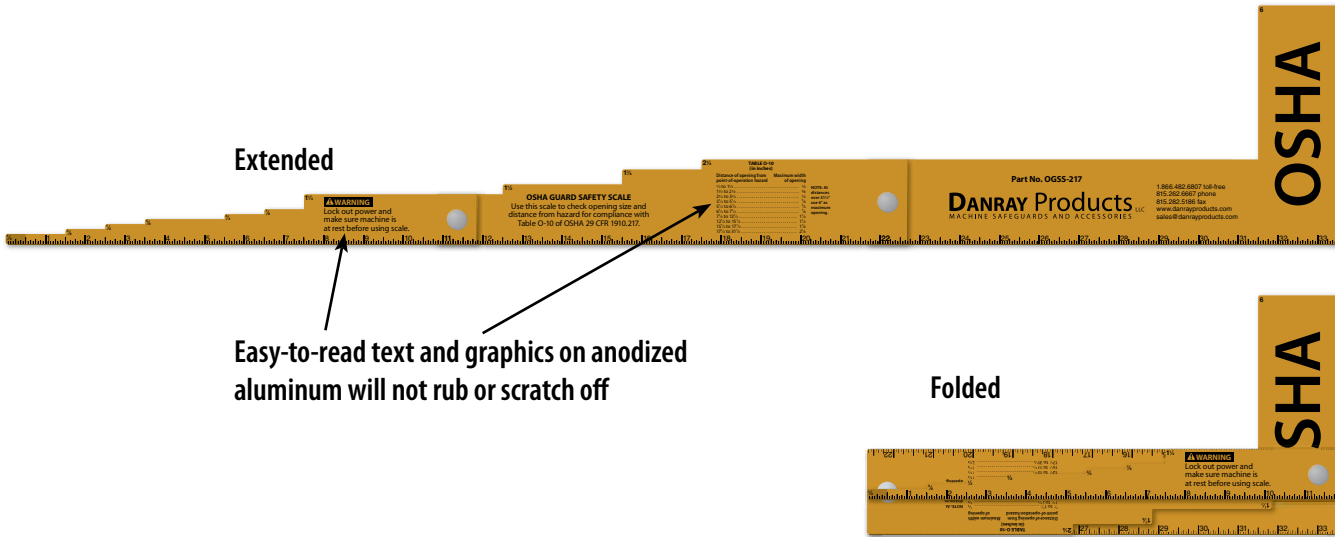

Point-of-operation barrier guards must be designed, constructed, applied, and adjusted so that individuals cannot reach through, over, under, or around the guards and reach the hazard. Most barrier guards have openings in them due to their design or because they are constructed out of materials such as wire mesh, expanded metal, rods, or hairpins. These openings must be checked for safety compliance.

Table O-10 and the Safe Openings Diagram of OSHA 29 CFR 1910.217 for mechanical power presses are used for reference when determining maximum guard openings and minimum mounting distances of barrier guards so that body parts such as hands and fingers cannot reach the hazard area. The dimensions in Table O-10 and the Safe Openings Diagram come from a series of

machine-guarding drawings developed by Liberty Mutual Insurance Company in the 1940s. These drawings represent the relationship between guard openings and mounting distances. The recommended dimensions in these drawings are based upon what was then termed "average-size hands."

ANSI incorporated the recommended dimensions from Liberty Mutual's machine-guarding drawings into its 1971 revision of the ANSI B11.1 safety standard for mechanical power presses. OSHA used ANSI B11.1-1971 as the basis for its own mechanical power presses standard, 1910.217, which was also published in 1971. Therefore, Liberty Mutual's machine-guarding drawings and their recommended dimensions were used for Table O-10 and the Safe Openings

Diagram of OSHA 29 CFR 1910.217, which remain unchanged and are still used today for compliance.

Our OSHA guard safety scale can check the openings in barrier guards for OSHA compliance. The yellow-colored, three-section folding scale has inches on both sides and includes the maximum permissible opening of six inches. It is made out of anodized aluminum and has easy-to-read text and graphics that will not rub or scratch off. It can be used during the design, installation, and inspection of barrier guards to make sure they comply with OSHA 29 CFR 1910.217.

OSHA Guard Safety Scale
Part No. OGSS-217
 Price: \$46.00

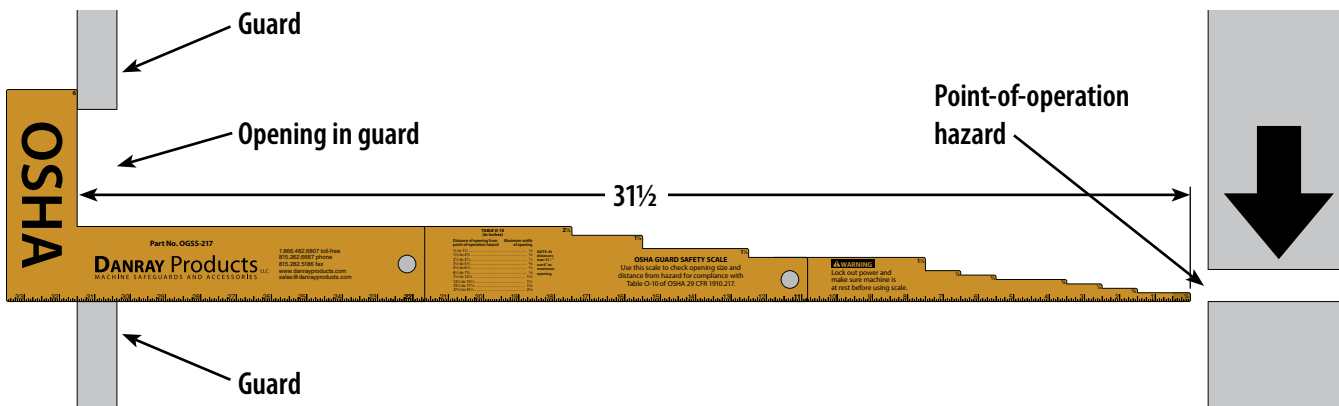

ANSI and CSA Guard Safety Scale



Easy-to-read text and graphics on anodized aluminum will not rub or scratch off

Folds in half for easy storage and handling

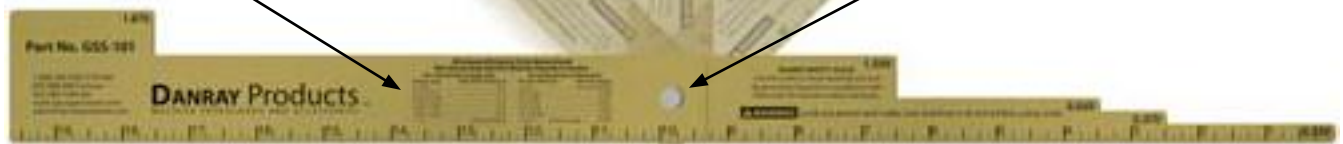

Point-of-operation barrier guards must be designed, constructed, applied, and adjusted so that individuals cannot reach through, over, under, or around the guards and reach the hazard. Most barrier guards have openings in them due to their design or because they are constructed out of materials such as wire mesh, expanded metal, rods, or hairpins. These openings must be checked for safety compliance.

ANSI (American National Standards Institute) and CSA (Canadian Standards Association) standards are used for reference when determining maximum guard openings and minimum mounting distances of barrier guards so that body parts such as hands and fingers cannot reach the hazard area.

Although an original study and drawings for machine guarding were created in the 1940s, it wasn't until the mid-1990s that a comparison of newer studies to the original drawings had been done. In 1995, a study entitled "A Review of Machine-Guarding Recommendations" was published in *Applied Ergonomics* (Vol. 26, No. 2, pp. 141-145); Donald R. Vaillancourt and Stover H. Snook of the Liberty Mutual Research Center for Safety and Health conducted this study. The purpose of their investigation was to determine whether the original drawings from the 1940s were still consistent with the data in the modern studies, especially relating to women and minorities, who are now much more prevalent in the American workplace. In their study, Vaillancourt and Snook compared data from six anthropometric surveys to the original machine-guarding recommendations.

Vaillancourt and Snook found many of the dimensions in the original drawings to be valid. However, they suggested several important modifications. Moreover, several of the dimensions from the original 1940s drawings showed no correlation to body reference points, so Vaillancourt and Snook suggested that they be eliminated.

The drawings from Vaillancourt and Snook's study have been adopted and are used in several current ANSI B11-series safety standards for machine tools as well as in the ANSI/RIA R15.06 safety standard for industrial robots and robot systems. The data from the study is also used by Canadian safety standards CSA Z142 for power presses, CSA Z434 for robots, and CSA Z432 for safeguarding of machinery.

Our ANSI and CSA guard safety scale can check the openings in barrier guards for ANSI and CSA compliance. The gold-colored, folding scale has inches on one side and millimeters on the other. It is made out of anodized aluminum and has easy-to-read text and graphics that will not rub or scratch off. It can be used during the design, installation, and inspection of barrier guards to make sure they comply with ANSI and CSA machine and robot safety standards.

ANSI and CSA Guard Safety Scale
Part No. GSS-101
Price: \$21.75



Checking a barrier guard that is in compliance.

Sander Safety Scale



Checking a disc sander that is in compliance.
(Shield removed for photo.)



Checking a belt sander that is in compliance.
(Shield removed for photo.)



Front



Back

OSHA requires employers to provide work and a workplace free from recognized hazards that could cause serious injury or death. Sanders (sometimes called grinders, especially when using them on metal) have moving belts and rotating discs that could snag, cut, dismember, and entrap, causing serious injury. Shields or other safeguards must be used to protect individuals. In addition, tables must be within 1/8" of the belt and disc to help prevent fingers and workpieces from being caught between the moving abrasive and the table.

Our sander safety scale can verify that the openings between the belt and disc and the tables are 1/8" or less. The bronze-colored scale is made out of durable, 0.090"-thick anodized aluminum and has easy-to-read text and graphics that will not rub or scratch off. It is about the size of a credit card, which makes it convenient to carry and store. There is a 0.25"-diameter hole in it for attachment to Sanders and a ruler along the back edge to measure openings for compliance.

Sander Safety Scale

Part No. SSS-350

Price: \$10.50

Bench Grinder Safety Scale



Checking a work rest that is not in compliance—the opening is greater than 1/8". (Shields removed for photo.)



Checking a tongue that is not in compliance—the opening is greater than 1/4". (Shields removed for photo.)



Front



Back

OSHA 29 CFR 1910.215 for grinders is one of the most frequently cited machine-safety standards for violations during OSHA machine-safety inspections. This is due to improperly adjusted work rests and tongues on bench grinders (sometimes called offhand or pedestal grinders). According to 29 CFR 1910.215(a)(4), work rests must be kept adjusted closely to the wheel with a maximum opening of 1/8" to prevent the workpiece from being jammed between the wheel and the rest, which may cause wheel breakage. In addition, 29 CFR 1910.215(b)(9) states that the distance between the wheel periphery and the adjustable tongue must never exceed 1/4".

Since many people are unaware of these OSHA-required adjustments for bench grinders, our U.S. Copyright Office-registered bench grinder safety scale can check the openings between the grinding wheels and the tongues and work rests for compliance with OSHA 29 CFR 1910.215 as well as the ANSI B11.9 and ANSI B7.1 grinder safety standards (which have the same requirements). This scale has a 0.25"-diameter hole in it for attachment to bench grinders for easy verification of the proper adjustments by employers and operators.

The orange-colored scale is made out of durable, 0.090"-thick anodized aluminum and has easy-to-read text and graphics that will not rub or scratch off. It is about the size of a credit card, which makes it convenient to carry and store. It can be used during the installation, maintenance, and inspection of bench grinders to make sure the work rests and tongues comply with OSHA and ANSI grinder safety standards, which can help reduce OSHA violations.

Bench Grinder Safety Scale Part No. BGSS-102

Price: \$10.50



Fan Guard Safety Scale



Checking a fan guard that is in compliance.

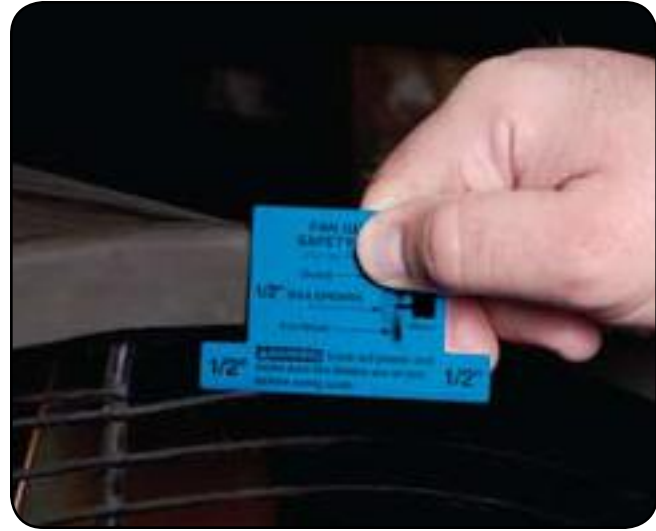

Checking a fan guard that is not in compliance—a piece of the wire guard is broken off, allowing more than a 1/2" opening.



Front



Back

According to OSHA 29 CFR 1910.212(a)(5), "When the periphery of the blades of a fan is less than seven (7) feet above the floor or working level, the blades shall be guarded. The guard shall have openings no larger than one-half (1/2) inch."

Our one-of-a-kind, U.S. Copyright Office-registered fan guard safety scale can easily check the openings in fan guards for OSHA compliance. The blue-colored scale is made out of durable, 0.090"-thick anodized aluminum, it has a 0.25"-diameter hole, and it has easy-to-read text and graphics that will not rub or scratch off. It is about the size of a credit card, which makes it convenient to carry and store.

Fan Guard Safety Scale

Part No. FGSS-150

Price: \$10.50



Point-of-Operation-Opening Safety Scale



Checking a point-of-operation opening that is in compliance.



Front



Back

OSHA 29 CFR 1910.217(c)(1)(i) requires point-of-operation guards or properly adjusted point-of-operation devices on every operation performed on a mechanical power press. However, according to 29 CFR 1910.217(c)(1)(ii), this requirement does not apply when the point-of-operation opening is 1/4" or less.

Point-of-Operation-Opening Safety Scale

Part No. POSS-250

Price: \$10.50

A 1/4" (6 mm) or less point-of-operation opening is common on machines that have a very short working stroke and in situations where the hazard has been designed out.

Our unique point-of-operation-opening safety scale can quickly check the point-of-operation opening for no safeguard required in accordance with OSHA 29 CFR 1910.217(c)(1)(ii) as well as applicable ANSI (American National Standards Institute) and CSA (Canadian Standards Association) machine safety standards. It has a tapered design allowing it to be used in tight, obstructive areas. The natural-aluminum scale is made out of durable, 0.090"-thick anodized aluminum, it has a 0.25"-diameter hole, and it has easy-to-read text and graphics that will not rub or scratch off. It is about the size of a credit card, which makes it convenient to carry and store.

Safety Signs



Our unique, U.S. Copyright Office-registered safety signs comply with OSHA 29 CFR 1910.145 and the ANSI Z535 series of standards. These polyester signs are 0.002" thick with a high-bond-strength acrylic adhesive back by 3M that has excellent chemical resistance and holding strength even at high temperatures (up to 350°F).

Cutting and Turning Machines

Bench Grinder Openings

Part No. LBL-001
Price: \$1.75
2½" W x 3½" H
With Adhesive Back



OSHA 29 CFR 1910.215 is the most cited safety standard for violations on bench grinders. The work rests must be adjusted to within 1/8" and the tongues within 1/4".

Cutting Machines

Part No. LBL-002
Price: \$4.25
5" W x 6" H
With Adhesive Back



This general sign identifies and warns of hazards associated with metal- and woodworking cutting machines.

Bench Grinders

Part No. LBL-006
Price: \$4.25
5" W x 6" H
With Adhesive Back

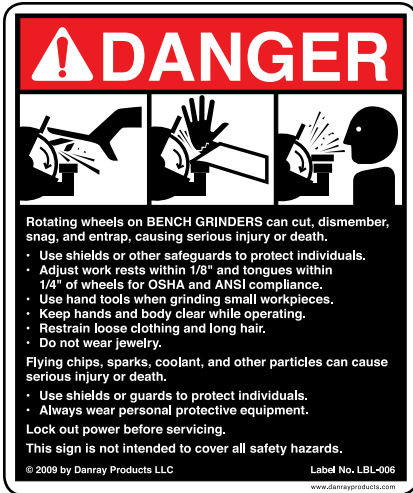

Common applications: Bench and pedestal grinders (sometimes called offhand grinders).

Sanders

Part No. LBL-024
Price: \$4.25
5" W x 6" H
With Adhesive Back



Common applications: Disc and belt sanders and grinders.

Surface Grinders

Part No. LBL-007
Price: \$4.25
5" W x 6" H
With Adhesive Back

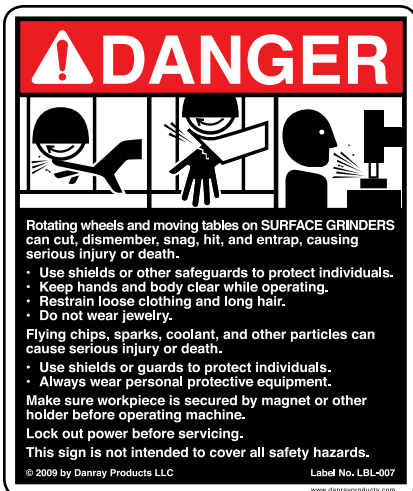

Drilling Machines

Part No. LBL-003
Price: \$4.25
5" W x 6" H
With Adhesive Back



Common applications: Manual and automatic metal- and woodworking drill presses, gang drills, and radial drills.

Safety Signs



Cutting and Turning Machines

Milling Machines

Part No. LBL-004
Price: \$4.25
5" W x 6" H
With Adhesive Back

Common applications:
Manual and automatic vertical and horizontal mills.

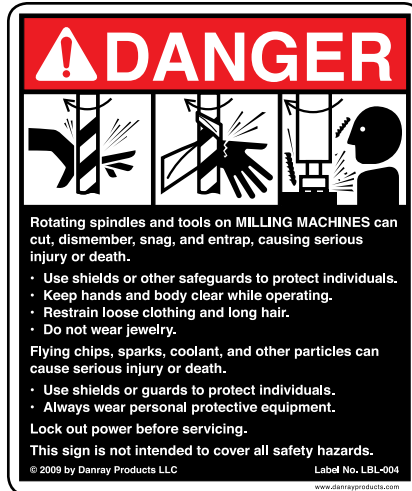

Sawing Machines

Part No. LBL-008
Price: \$4.25
5" W x 6" H
With Adhesive Back

Common applications:
Manual and automatic metal- and woodworking band (vertical and horizontal), table, and radial saws.



Lathes

Part No. LBL-005
Price: \$4.25
5" W x 6" H
With Adhesive Back

Common applications:
Manual and automatic engine and turret lathes.



Fabricating Machines

Power Presses

Part No. LBL-010
Price: \$4.25
5" W x 6" H
With Adhesive Back

Part No. LBL-031
Price: \$8.75
8¾" W x 10½" H
With Adhesive Back

Common applications:
Mechanical, hydraulic, servo, and pneumatic power presses.



Power Press Brakes

Part No. LBL-011
Price: \$8.75
8¾" W x 10½" H
With Adhesive Back

Common applications:
Mechanical, hydraulic, servo, and pneumatic power press brakes.



Safety Blocks

Part No. LBL-009
Price: \$4.25
5" W x 6" H
With Adhesive Back

Common applications:
On safety blocks or close to their storage location.



Safety Signs



Fabricating Machines

Shears

Part No. LBL-012
Price: \$4.25
5" W x 6" H
With Adhesive Back

Part No. LBL-032
Price: \$8.75
8¾" W x 10½" H
With Adhesive Back

Common applications:
Plate and squaring shears.



Ironworkers

Part No. LBL-013
Price: \$4.25
5" W x 6" H
With Adhesive Back

Common applications:
Mechanical and hydraulic ironworkers.



Spot Welders

Part No. LBL-017
Price: \$4.25
5" W x 6" H
With Adhesive Back

Common applications:
Spot (resistance) welders.



Riveters

Part No. LBL-014
Price: \$4.25
5" W x 6" H
With Adhesive Back

Common applications:
Mechanical and pneumatic riveters.



Roll Benders

Part No. LBL-015
Price: \$4.25
5" W x 6" H
With Adhesive Back

Part No. LBL-033
Price: \$8.75
8¾" W x 10½" H
With Adhesive Back

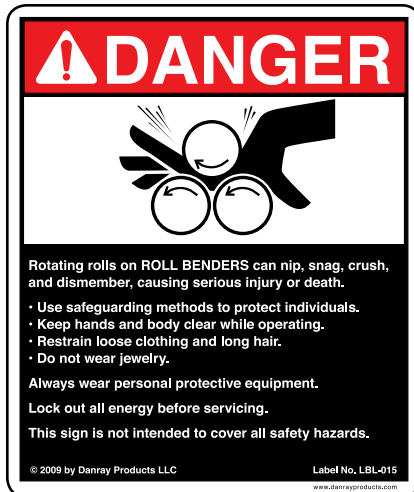

Roll Formers

Part No. LBL-016
Price: \$4.25
5" W x 6" H
With Adhesive Back

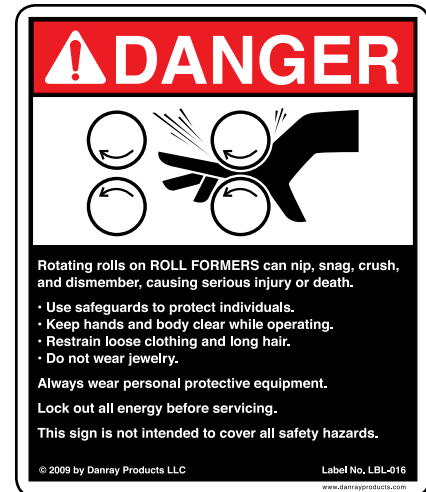

Safety Signs



Other Machines

Fastener Machines

Headers

Part No. LBL-018
Price: \$4.25
5" W x 6" H
With Adhesive Back



Roll Threaders

Part No. LBL-019
Price: \$4.25
5" W x 6" H
With Adhesive Back



Robots

Robots

Part No. LBL-022
Price: \$8.75
8¾" W x 10½" H
With Adhesive Back



Robot Welders

Part No. LBL-023
Price: \$8.75
8¾" W x 10½" H
With Adhesive Back



Molding and Die Casting Machines

Plastic Injection Molding Machines

Part No. LBL-020
Price: \$8.75
8¾" W x 10½" H
With Adhesive Back

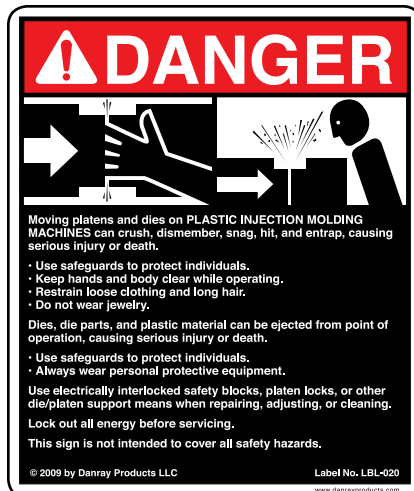

Die Casting Machines

Part No. LBL-021
Price: \$8.75
8¾" W x 10½" H
With Adhesive Back



Safety Signs



Mechanical Power-Transmission Apparatuses

Gears

Part No. LBL-025
Price: \$4.25
5" W x 6" H
With Adhesive Back



Rolls

Part No. LBL-026
Price: \$4.25
5" W x 6" H
With Adhesive Back



Flywheels

Part No. LBL-027
Price: \$4.25
5" W x 6" H
With Adhesive Back



Pulleys and Belts

Part No. LBL-028
Price: \$4.25
5" W x 6" H
With Adhesive Back



Sprockets and Chains

Part No. LBL-030
Price: \$4.25
5" W x 6" H
With Adhesive Back



Drive Shafts

Part No. LBL-029
Price: \$4.25
5" W x 6" H
With Adhesive Back



Polycarbonate Sign Backings



SB-0607 polycarbonate sign backing.



SB-0607 polycarbonate sign backing shown with LBL-029 sign adhered (sign sold separately; see previous page).



Adhering sign to backing.

Our polycarbonate sign backings are for the safety signs shown on pages 8–12. The backing is 0.060"-thick clear polycarbonate.

To adhere the sign to the polycarbonate sign backing, first remove the protective masking on both sides of the polycarbonate. Second, remove the slit adhesive liner on the backside of the sign. Third, line up the sign above the polycarbonate, allowing for a 1/2" margin on all sides of the sign. Finally, attach a side or corner of the sign onto the polycarbonate and smoothly swipe your hand or fingers over it from one end to the other, as shown. This will prevent air bubbles from forming under the sign.

To attach the polycarbonate-backed sign to a machine or other equipment, use tape, glue, rivets, screws, or other fasteners.

Part No. SB-0607

Polycarbonate sign backing 6" W x 7" H x 0.060" thick (for 5" W x 6" H safety signs). **Price: \$4.50**

Part No. SB-1012

Polycarbonate sign backing 9 3/4" W x 11 1/2" H x 0.060" thick (for 8 3/4" W x 10 1/2" H safety signs). **Price: \$7.75**

Roller Shields



These roller shields are designed for lathes or similar machines. They provide a safeguard between individuals and rotating hazards by helping prevent clothing, hair, etc., from being pulled into the leadscrew and other shafts below the bed of the lathe.

Roller shields can also be used on numerous other machines. They can be mounted horizontally (as on a lathe), vertically, or at any angle depending on the application. The shields are priced individually. A typical lathe will need two roller shields (one for each side of the carriage).

The roller shield is furnished in a steel enclosure with a clock-type, spring-loaded rewind inside for the fabric. The 0.5-mm-thick fabric is made of polyester coated on both sides with polyurethane (PUR/PES/PUR). It is resistant to cutting oils, coolant, and chips, and there is a wiper that removes excess liquid and chips as it enters the enclosure.

On lathes, the roller shield boxes are usually mounted to the far left and far right on the front of the machine. The fabric plate is fastened to the carriage directly or with an optional mounting bracket. When measuring for the length

of the fabric, be sure to measure when the carriage is at its farthest left and right positions. Make sure that there will be enough room for the box and fabric when the carriage is at its farthest left, where a majority of machining is done. If there isn't enough room, the box will need to be mounted on the front of the headstock. To determine the height of fabric, measure the height of the area where the shafts are located. Please see the chart on the next page for sizes of roller shields available.



Note: The mounting tabs on the roller shield boxes and the optional mounting brackets are intentionally left blank. Holes will need to be drilled and mounting brackets may need to be fabricated or furnished to mount the shield to the machine. Each box is furnished with seven ¼"-20 x ¾" long hex-head cap screws, seven ¼" washers, and seven ¼" locknuts.

Roller Shields

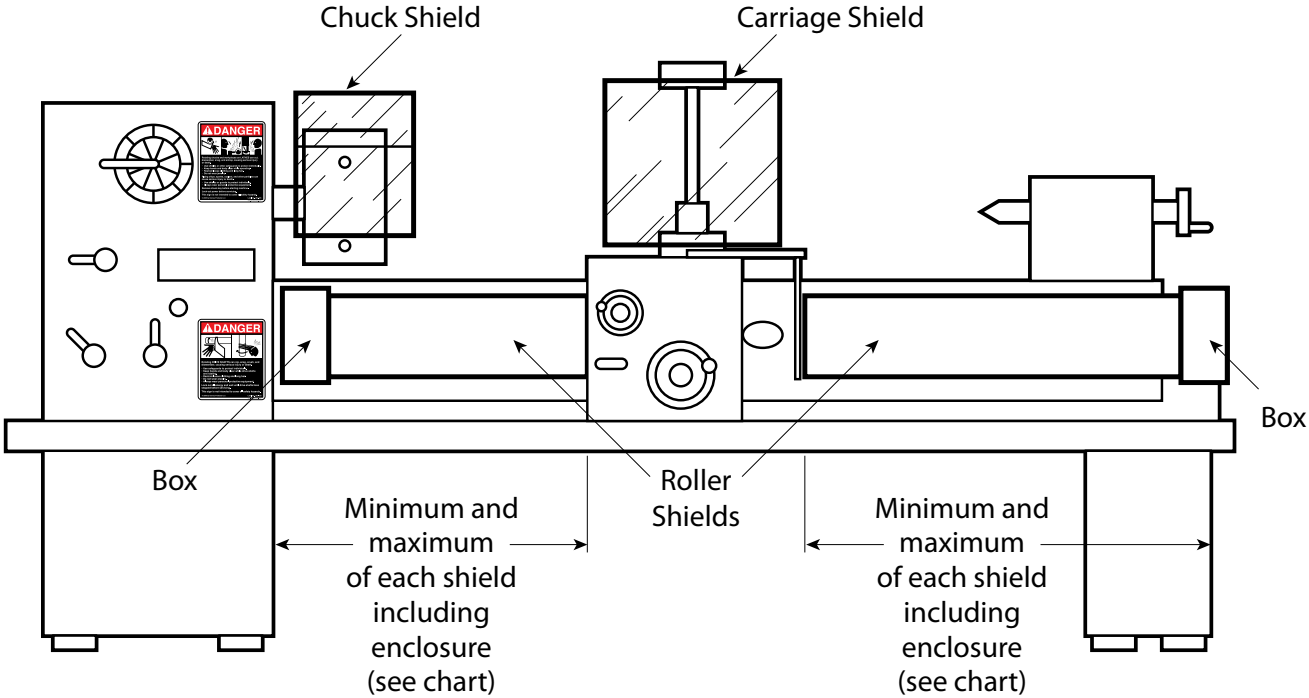

Part No.	Minimum opening (including box)	Maximum opening (including box)	Box height	Fabric height	Price (per box)*
RS-640	4"	40"	8"	6"	\$ 434.00
RS-880	5"	80"	10"	8"	484.00
RS-10100	5"	100"	12"	10"	586.00
RS-12200	6½"	200"	14"	12"	938.00
RS-14250	6½"	250"	16"	14"	1,038.00

Custom shields are available on request.

*In most cases, two roller shield boxes are needed on lathes (one for the left and one for the right of the carriage).

Shown at the right are the optional mounting brackets for attaching roller shields to a lathe or other machine. The flat brackets are ½"-thick steel and the right-angle brackets are 1½"-wide, ¼"-thick steel. These optional brackets will need to be fabricated to fit the roller shield to the machine.

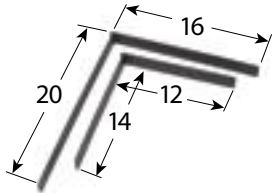
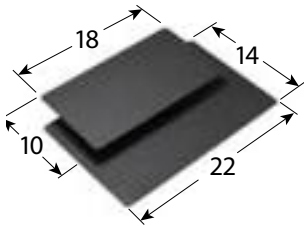

Part No.		
BKT-1018	Flat Bracket 10" W x 18" H x ½" Thick	\$42.00
BKT-1422	Flat Bracket 14" W x 22" H x ½" Thick	\$46.00
BKT-1214	Right-Angle Bracket 12" x 14" x 1½" x ¼" Thick	\$54.00
BKT-1620	Right-Angle Bracket 16" x 20" x 1½" x ¼" Thick	\$59.00

Poly. Lathe Chuck Shields



These heavy-duty 3/16"-thick polycarbonate lathe chuck shields are designed for lathes or similar machines. They serve two basic functions: (1) they provide a safeguard between individuals and point-of-operation or rotating hazards, and (2) they protect individuals from flying chips, sparks, coolant, lubricant, and other particles. The mounting bracket attaches

to the face of the headstock. The shield hinges left and rests at a 45° angle above the headstock, making it easy to change or adjust the chuck or workpiece. The operator doesn't need to reach over the chuck to move the shield in and out of position, and the shield will not interfere with lathes that have a rear guard/backsplash.

Shield for 6" Chucks and Smaller

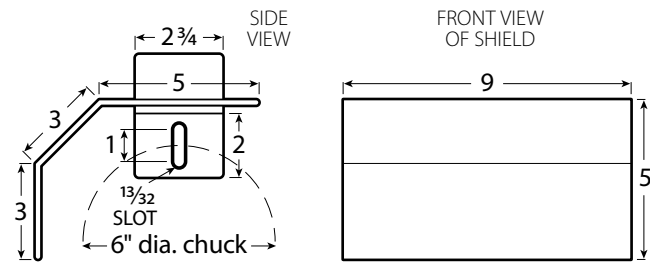

Part No. SHD-119L
 Assembly consisting of the 3/16"-thick polycarbonate shield, 1/4"-thick steel mounting bracket, hinge, fasteners, and safety sign. Price: \$137.00

Shields for 12" Chucks and Smaller

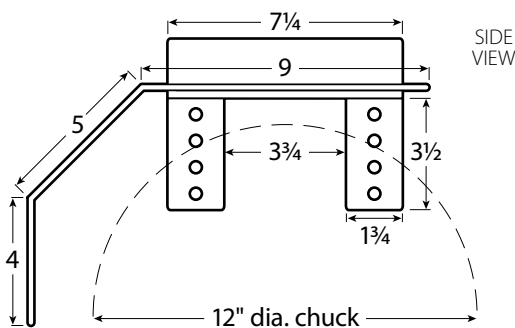

Part No. SHD-1812L
 Assembly consisting of the 3/16"-thick polycarbonate shield, 1/4"-thick steel mounting bracket, hinges, fasteners, and safety sign. Price: \$190.00

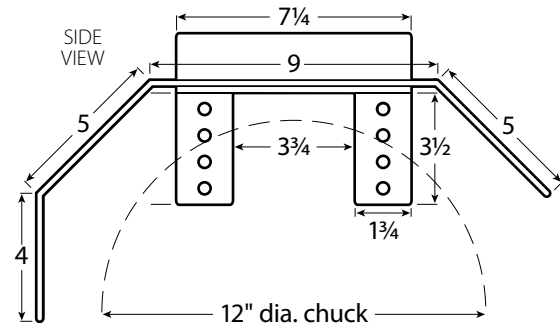
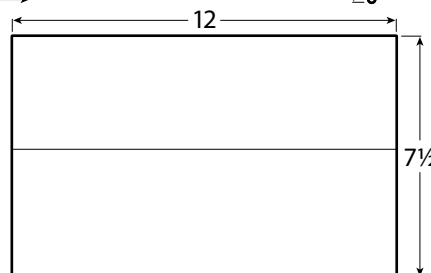

Part No. SHD-2312L
 Assembly consisting of the 3/16"-thick polycarbonate shield, 1/4"-thick steel mounting bracket, hinges, fasteners, and safety sign. Price: \$201.00

Poly. Lathe Chuck Shields



Shield for 18" Chucks and Smaller

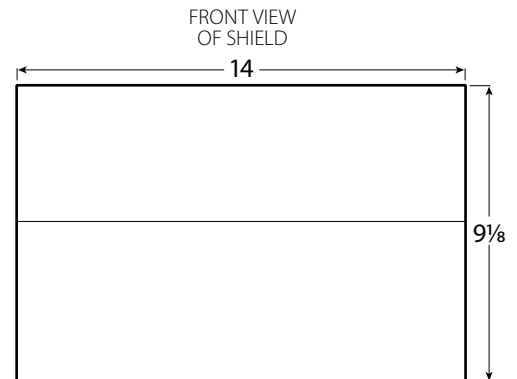
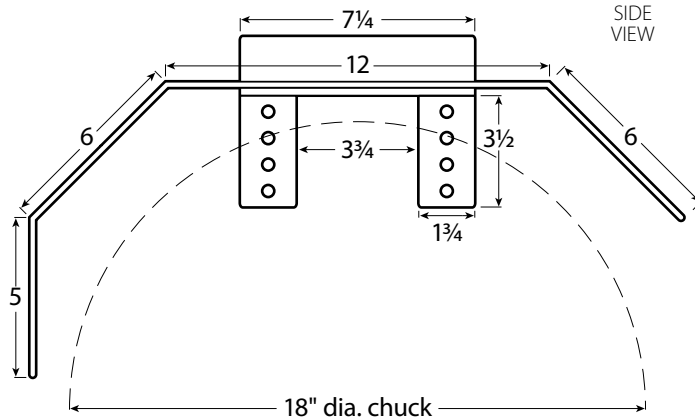

Part No. SHD-2914L

Assembly consisting of the $\frac{3}{16}$ "-thick polycarbonate shield, $\frac{1}{4}$ "-thick steel mounting bracket, hinges, fasteners, and safety sign. Price: \$219.00

Shield for 24" Chucks and Smaller



Part No. SHD-4016L

Assembly consisting of the $\frac{3}{16}$ "-thick polycarbonate shield, $\frac{1}{4}$ "-thick steel mounting bracket, hinges, fasteners, and safety sign. Price: \$319.00

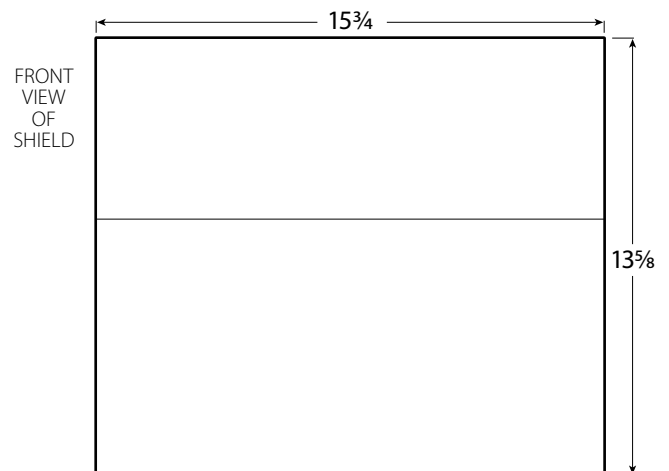
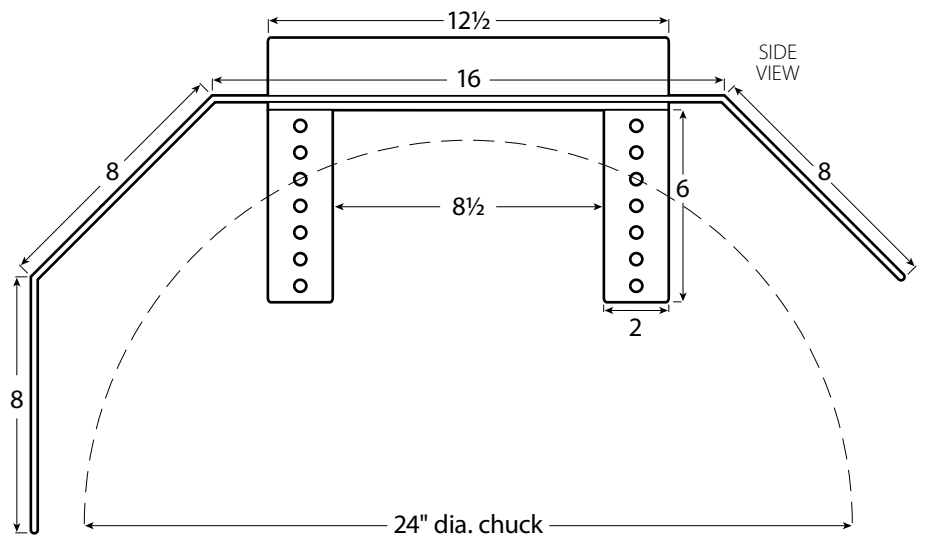

Safety Sign for Lathes

One LBL-005 sign is included with every lathe shield assembly, but this sign can also be purchased separately.

Part No. LBL-005
5" W x 6" H With Adhesive Back.
Price: \$4.25

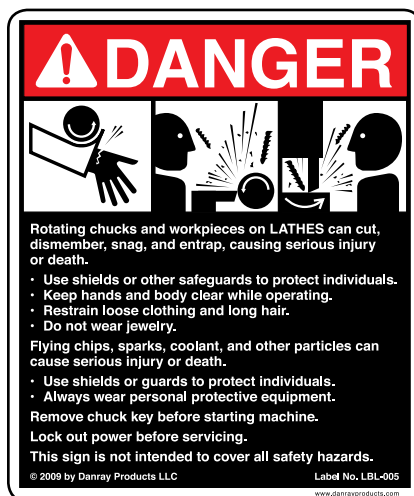

Steel Lathe Chuck Shields



These heavy-duty 14-gauge steel lathe chuck shields are designed for lathes or similar machines. They serve two basic functions: (1) they provide a safeguard between individuals and point-of-operation or rotating hazards, and (2) they protect individuals from flying chips, sparks, coolant, lubricant, and other particles. The mounting

bracket attaches to the face of the headstock. The shield hinges left and rests at a 45° angle above headstock, making it easy to change or adjust the chuck or workpiece. The operator doesn't need to reach over the chuck to move the shield in and out of position, and the shield will not interfere with lathes that have a rear guard/backsplash.

Shield for 12" Chucks and Smaller

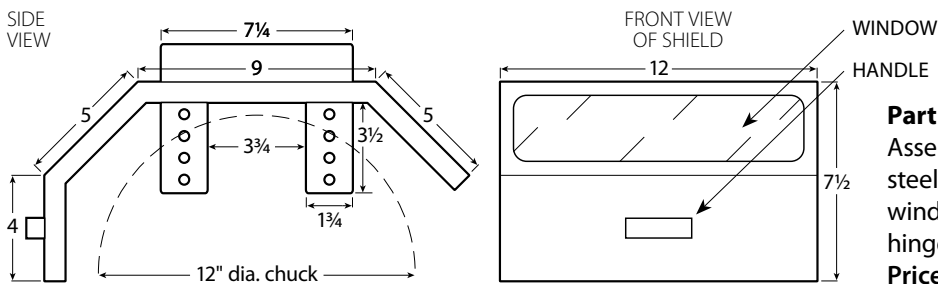

Part No. SHD-2312LSF

Assembly consisting of the 14-gauge steel shield with $\frac{3}{16}$ "-thick polycarbonate window, $\frac{1}{4}$ "-thick steel mounting bracket, hinges, fasteners, and safety sign.

Price: \$352.00

Shield for 18" Chucks and Smaller

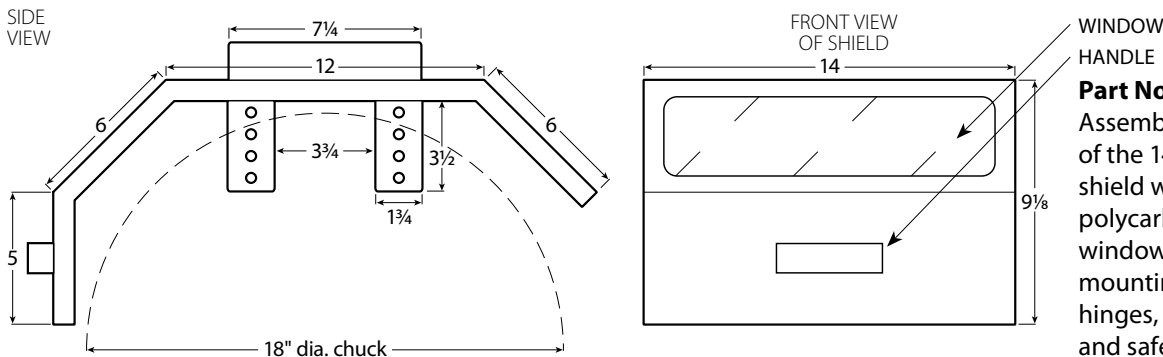

Part No. SHD-2914LSF

Assembly consisting of the 14-gauge steel shield with $\frac{3}{16}$ "-thick polycarbonate window, $\frac{1}{4}$ "-thick steel mounting bracket, hinges, fasteners, and safety sign.

Price: \$384.00

Steel Lathe Chuck Shields



Shield for 24" Chucks and Smaller

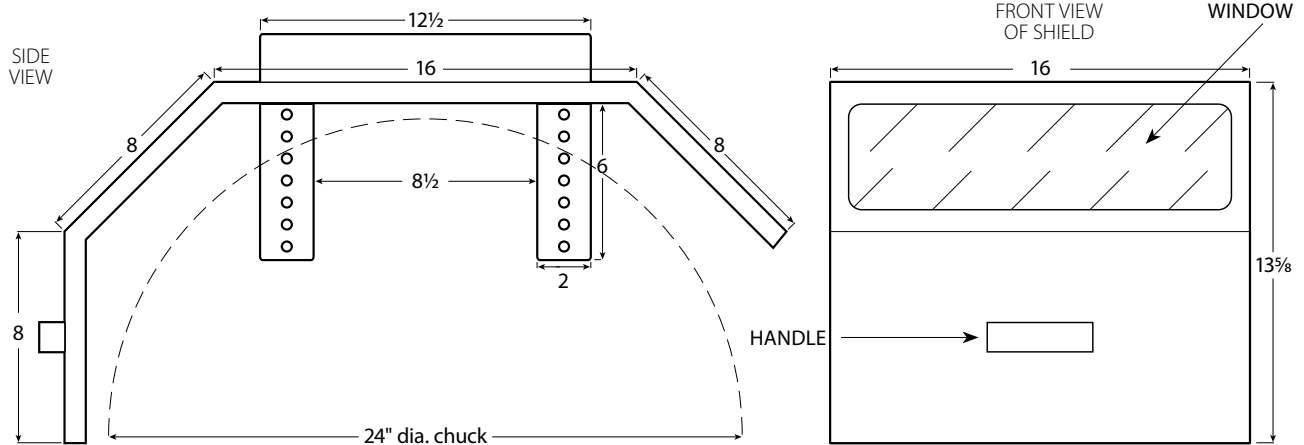

Part No. SHD-4016LSF

Assembly consisting of the 14-gauge steel shield with $\frac{3}{16}$ "-thick polycarbonate window, $\frac{1}{4}$ "-thick steel mounting bracket, hinges, fasteners, and safety sign. Price: \$416.00

Replacement Shields Only

The following are replacement shields only for the assemblies shown on pages 18 and 19. These steel replacement shields can also replace polycarbonate shields previously furnished. These shields fit all polycarbonate shield hardware previously supplied.

RSA-2312LSF Shield Only for Lathe Chuck Diameter of 12" and Smaller
(for SHD-2312LSF and SHD-2312L) \$254.00

RSA-2914LSF Shield Only for Lathe Chuck Diameter of 18" and Smaller
(for SHD-2914LSF and SHD-2914L) \$265.00

RSA-4016LSF Shield Only for Lathe Chuck Diameter of 24" and Smaller
(for SHD-4016LSF and SHD-4016L) \$276.00

Replacement Windows Only

RSO-1104W Window Only for SHD-2312LSF \$25.00

RSO-1305W Window Only for SHD-2914LSF \$27.00

RSO-1507W Window Only for SHD-4016LSF \$34.00

Safety Sign for Lathes

One LBL-005 sign is included with every lathe shield assembly, but this sign can also be purchased separately.

Part No. LBL-005

5" W x 6" H With Adhesive Back.

Price: \$4.25



Steel Lathe Chuck Shields

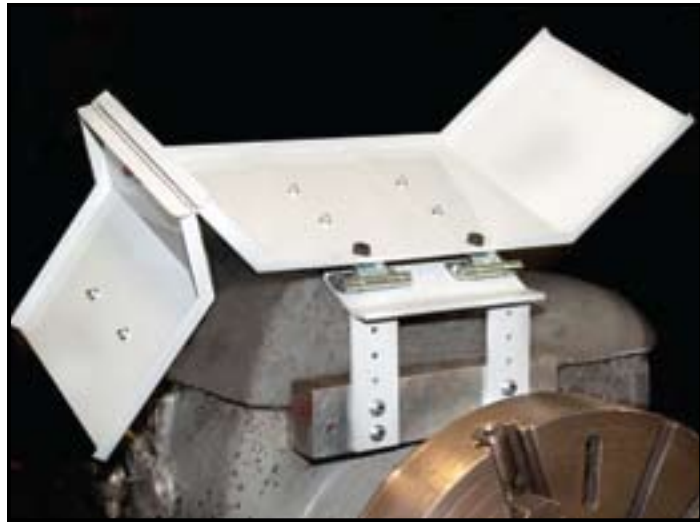
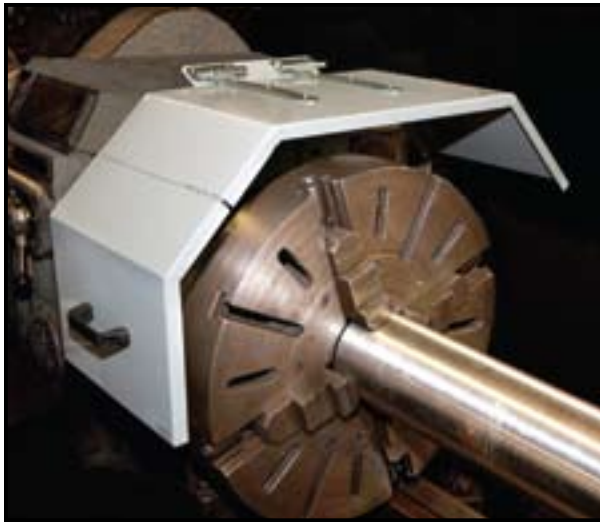

These heavy-duty 14-gauge steel lathe chuck shields are designed for lathes or similar machines. They serve two basic functions: (1) they provide a safeguard between individuals and point-of-operation or rotating hazards, and (2) they protect individuals from flying chips, sparks, coolant, lubricant, and other particles. The

mounting bracket attaches to the face of the headstock. The shield hinges left and rests at a 30° angle above the headstock, making it easy to change or adjust the chuck or workpiece. The operator doesn't need to reach over the chuck to move the shield in and out of position, and the shield will not interfere with lathes that have a rear guard/backsplash.

Shield for 32" Chucks and Smaller

Part No. SHD-5516L

Assembly consisting of the 14-gauge steel shield, 3/8"-thick steel mounting bracket, hinges, fasteners, and safety sign. Price: \$748.00

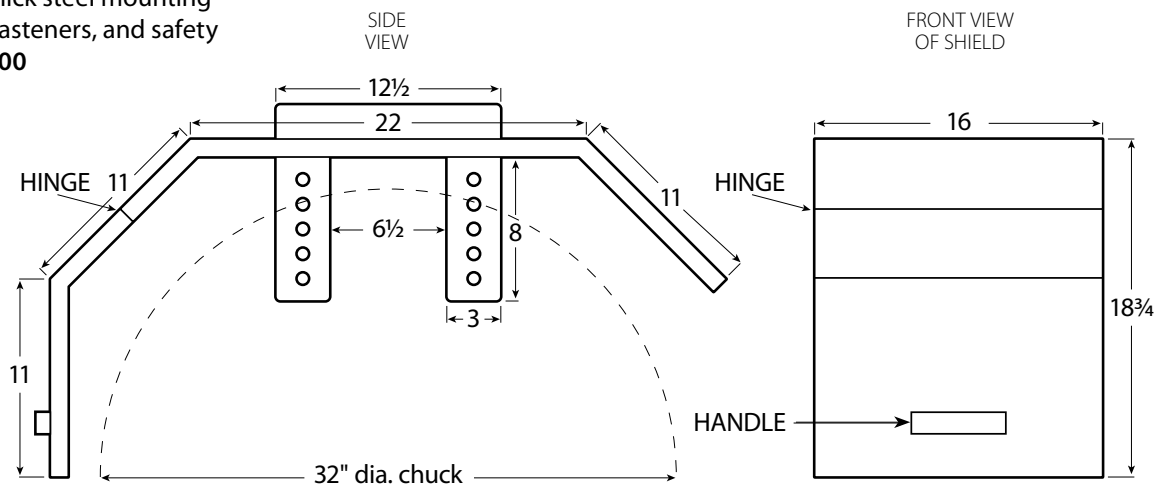

Steel Lathe Chuck Shields



The front portion of the shield can be hinged up, making it easy to change or adjust the workpiece. This eliminates having to hinge the entire shield over the headstock (as shown on the previous page).



Safety Sign for Lathes

One LBL-005 sign is included with every lathe shield assembly, but this sign can also be purchased separately.

Part No. LBL-005

5" W x 6" H With Adhesive Back.

Price: \$4.25

Shield for 40" Chucks and Smaller

Part No. SHD-6516L

Assembly consisting of the 14-gauge steel shield, $\frac{3}{8}$ "-thick steel mounting bracket, hinges, fasteners, and safety sign. **Price: \$768.00**

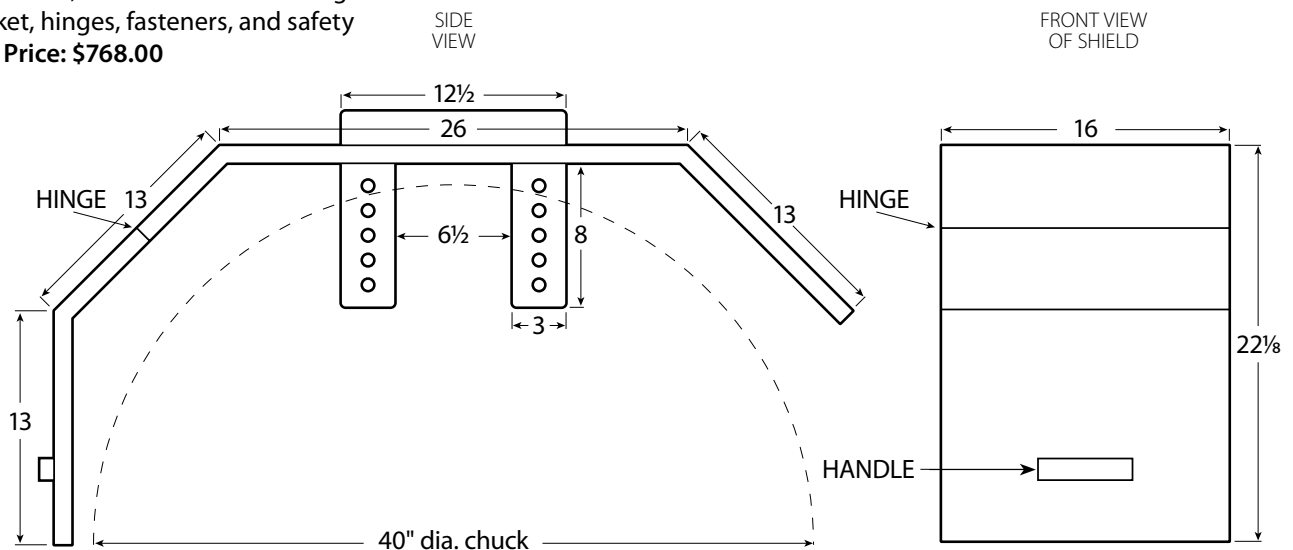

Steel Lathe Chuck Shields



These heavy-duty 12-gauge steel lathe chuck shields are designed for lathes or similar machines. They serve two basic functions: (1) they provide a safeguard between individuals and point-of-operation or rotating hazards, and (2) they protect individuals from flying chips, sparks, coolant, lubricant, and other particles. The mounting bracket attaches to the face

of the headstock. The vertical shield hinges like a door, making it easy to change or adjust the chuck or workpiece. The operator doesn't need to reach in close to the chuck when opening and closing the shield. The shield can be used on the front or back of the machine to safeguard the chuck. The shield design allows the shield to be hinged either left or right.

Steel Lathe Chuck Shields



Shield for 52" Chucks and Smaller

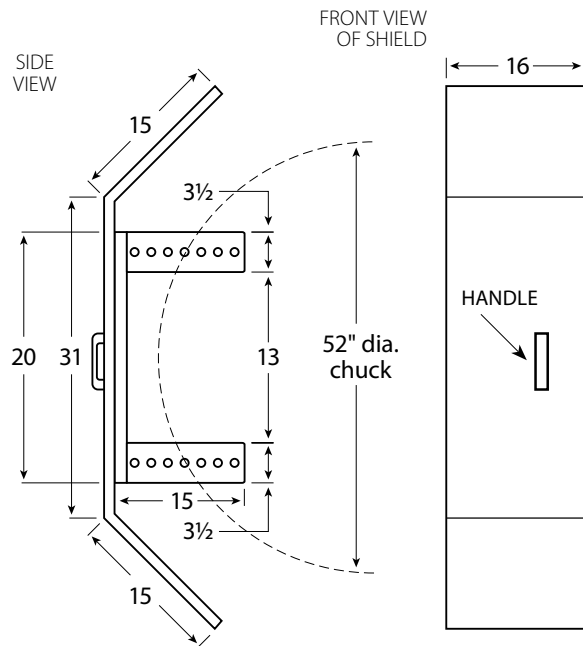

Part No. SHD-6116L

Assembly consisting of the 12-gauge steel shield, $\frac{3}{8}$ "-thick steel mounting bracket, hinges, fasteners, and safety sign.
Price: \$1,393.00

Shield for 62" Chucks and Smaller

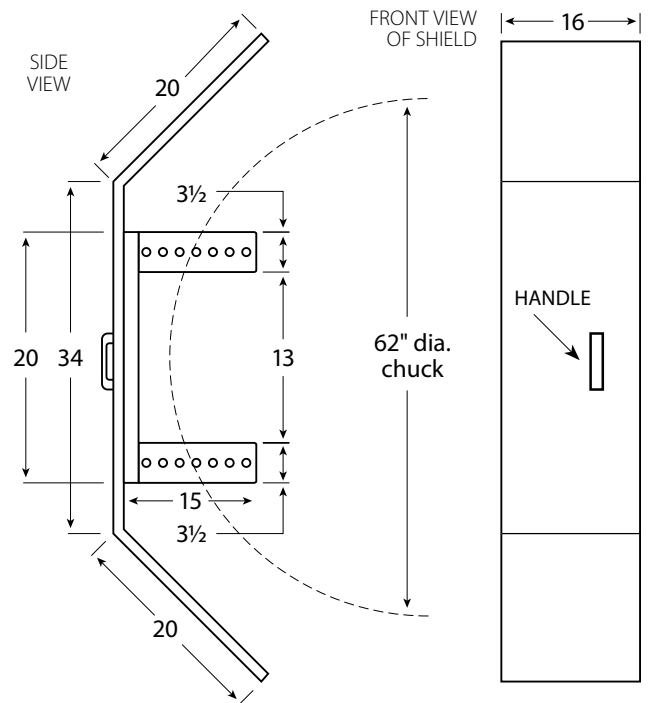

Part No. SHD-7416L

Assembly consisting of the 12-gauge steel shield, $\frac{3}{8}$ "-thick steel mounting bracket, hinges, fasteners, and safety sign.
Price: \$1,452.00

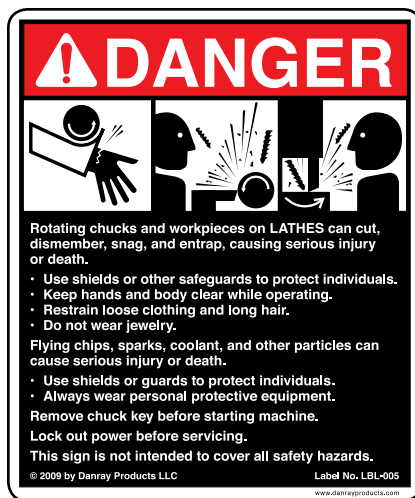

Safety Sign for Lathes

One LBL-005 sign is included with every lathe shield assembly, but this sign can also be purchased separately.

Part No. LBL-005

5" W x 6" H With Adhesive Back.

Price: \$4.25

Shields for larger chucks available upon request.

Lathe Carriage Shields



These heavy-duty lathe carriage (saddle) shields are designed for manual lathes or similar machines. They serve two basic functions: (1) they provide a safeguard between individuals and point-of-operation or rotating hazards, and (2) they protect individuals from flying chips, sparks, coolant, lubricant, and other particles. The mounting bracket attaches directly to the backside of the carriage so the shield moves with the carriage as the workpiece is being machined. The shield hinges back and rests at a 45° angle, making it easy to change the workpiece.

Shield for Lathes With 8" Chucks and Smaller

Part No. SHD-1612C

Assembly consisting of the 3/16"-thick polycarbonate shield, 1/4"-thick steel mounting brackets, hinge, fasteners, and safety sign.

Price: \$272.00

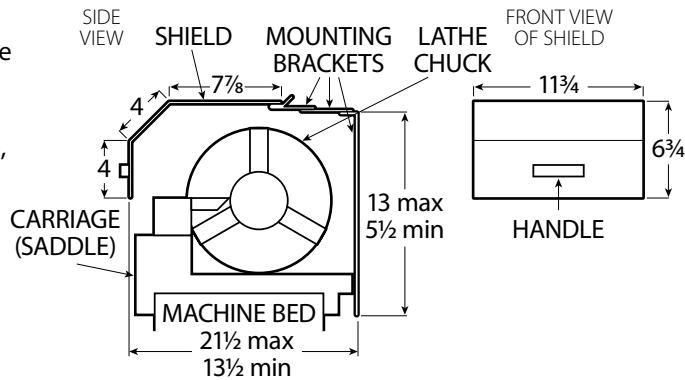

Shield for Lathes With 15" Chucks and Smaller

Part No. SHD-2816C

Assembly consisting of the 1/4"-thick polycarbonate shield, 1/4"-thick steel mounting brackets, hinges, fasteners, and safety sign.

Price: \$368.00

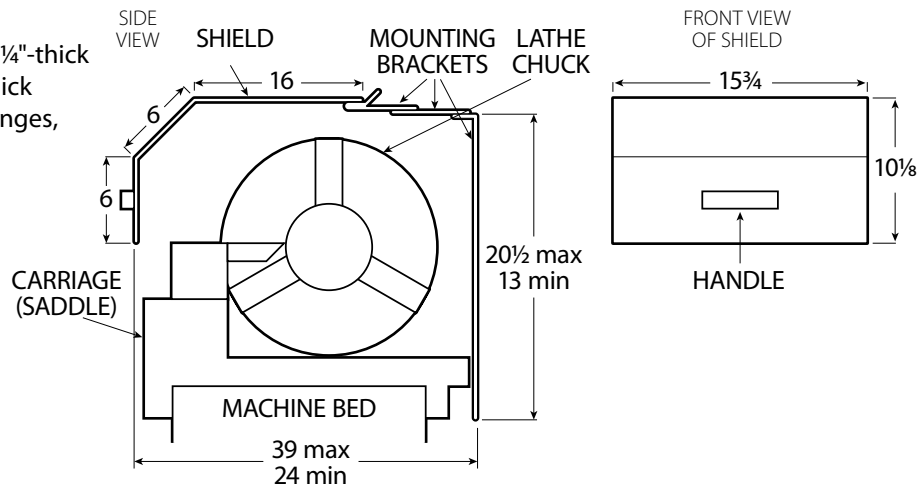

Lathe Carriage Shields



Shield for Lathes With 20" Chucks and Smaller

Part No. SHD-3516C

Assembly consisting of the ¼"-thick polycarbonate shield, ¼"-thick steel mounting brackets, hinges, fasteners, and safety sign.
Price: \$413.00

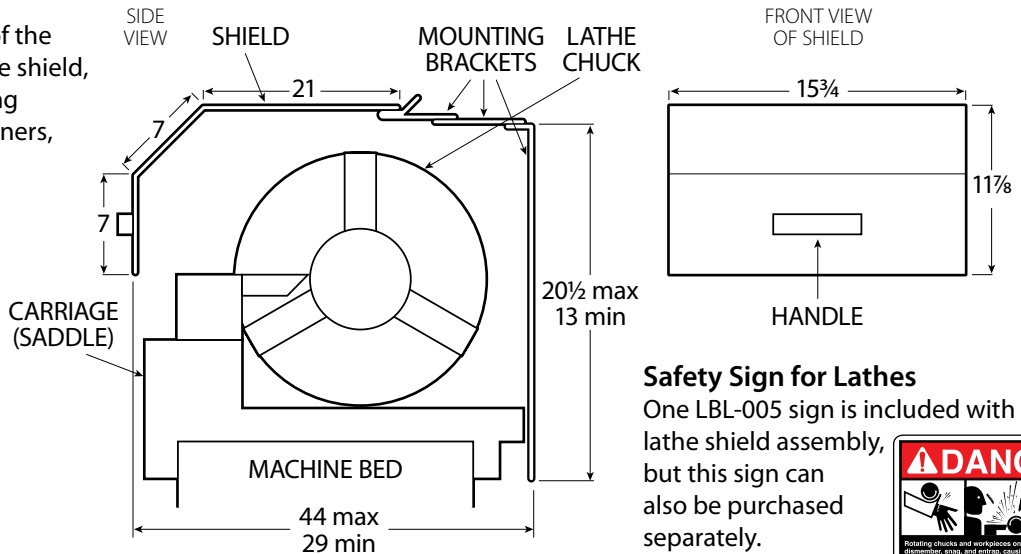

Safety Sign for Lathes

One LBL-005 sign is included with every lathe shield assembly, but this sign can also be purchased separately.



Part No. LBL-005

5" W x 6" H With Adhesive Back.
Price: \$4.25

Shield for Lathes With 28" Chucks and Smaller

Part No. SHD-4120C

Assembly consisting of the ¼"-thick polycarbonate shield, ⅜"-thick steel mounting brackets, hinges, fasteners, and safety sign.
Price: \$604.00

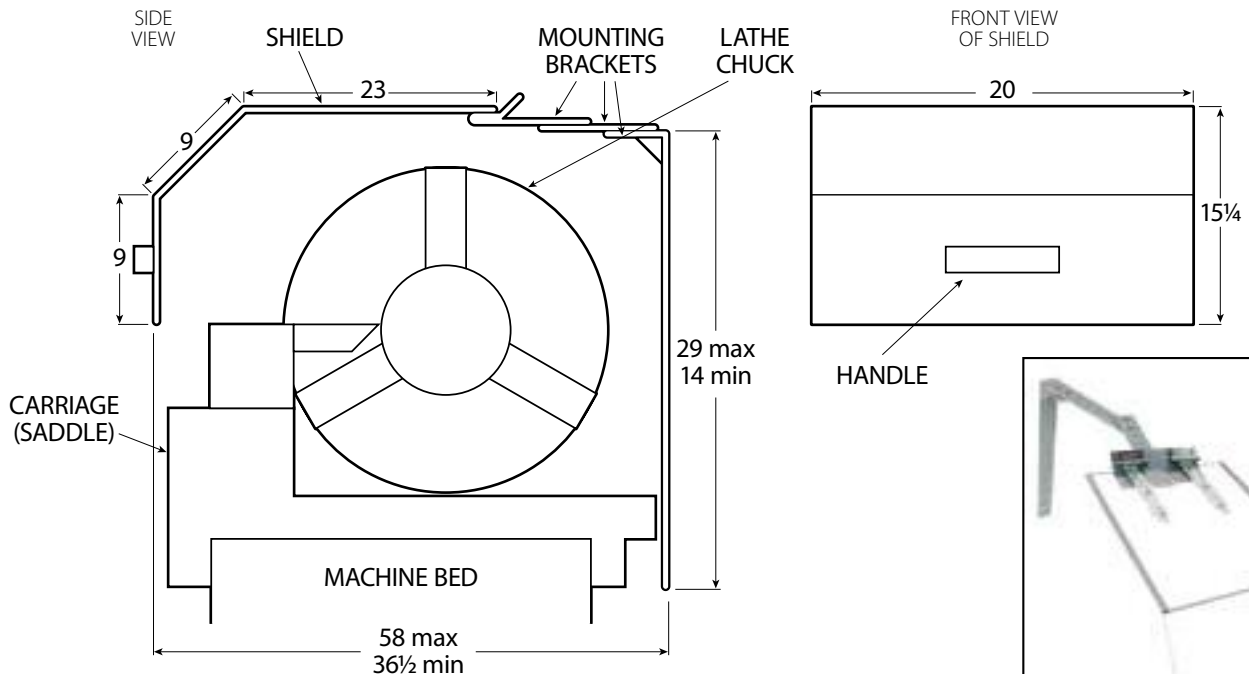

Wood Lathe Shields



These heavy-duty wood lathe shields are designed for manual wood lathes or similar machines (such as small metalworking lathes). They serve two basic functions: (1) they provide a safeguard between individuals and point-of-operation or rotating hazards, and (2) they protect individuals from flying chips as well as minimize the possibility of injury from a thrown workpiece. The mounting bracket attaches directly to

the backside of the machine bed. The shield hinges back and rests at a 45° angle, making it easy to change the workpiece.

For additional protection, the backside of the lathe can be safeguarded with an optional rear shield as shown above; see the bottom of the next page.

Shield for 24"-Long Working Area and Smaller

Part No. SHD-1024LW

Assembly consisting of the 3/16"-thick polycarbonate shield, 1/4"-thick steel mounting brackets, hinge, spacers, fasteners, and safety sign.

Price: \$289.00

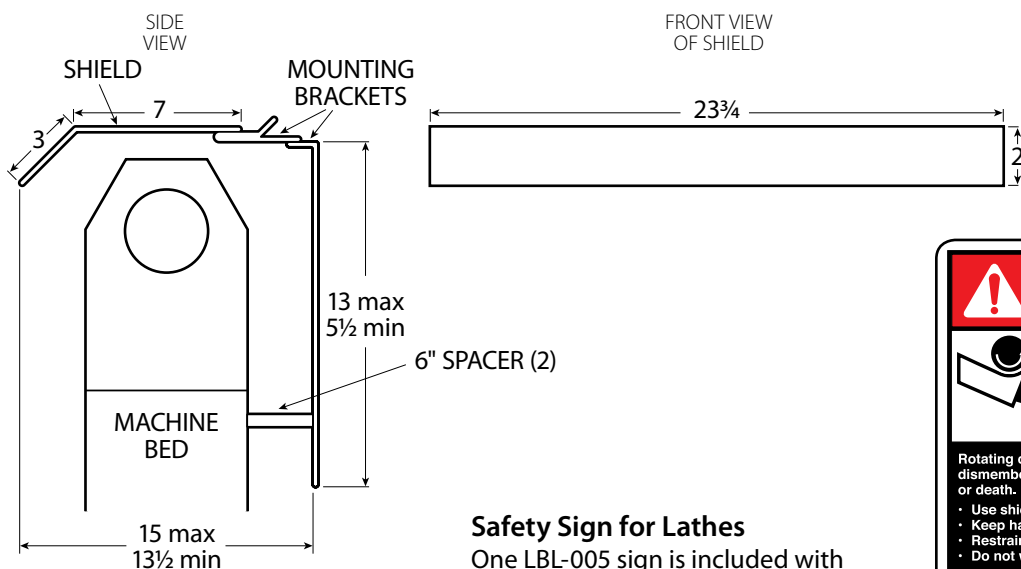

Safety Sign for Lathes

One LBL-005 sign is included with every lathe shield assembly, but this sign can also be purchased separately.

Part No. LBL-005

5" W x 6" H With Adhesive Back.

Price: \$4.25



Wood Lathe Shields



Shield for 42"-Long Working Area and Smaller

Part No. SHD-1642LW

Assembly consisting of the 1/4"-thick polycarbonate shield, 1/4"-thick steel mounting brackets, hinges, spacers, fasteners, and safety sign.

Price: \$499.00

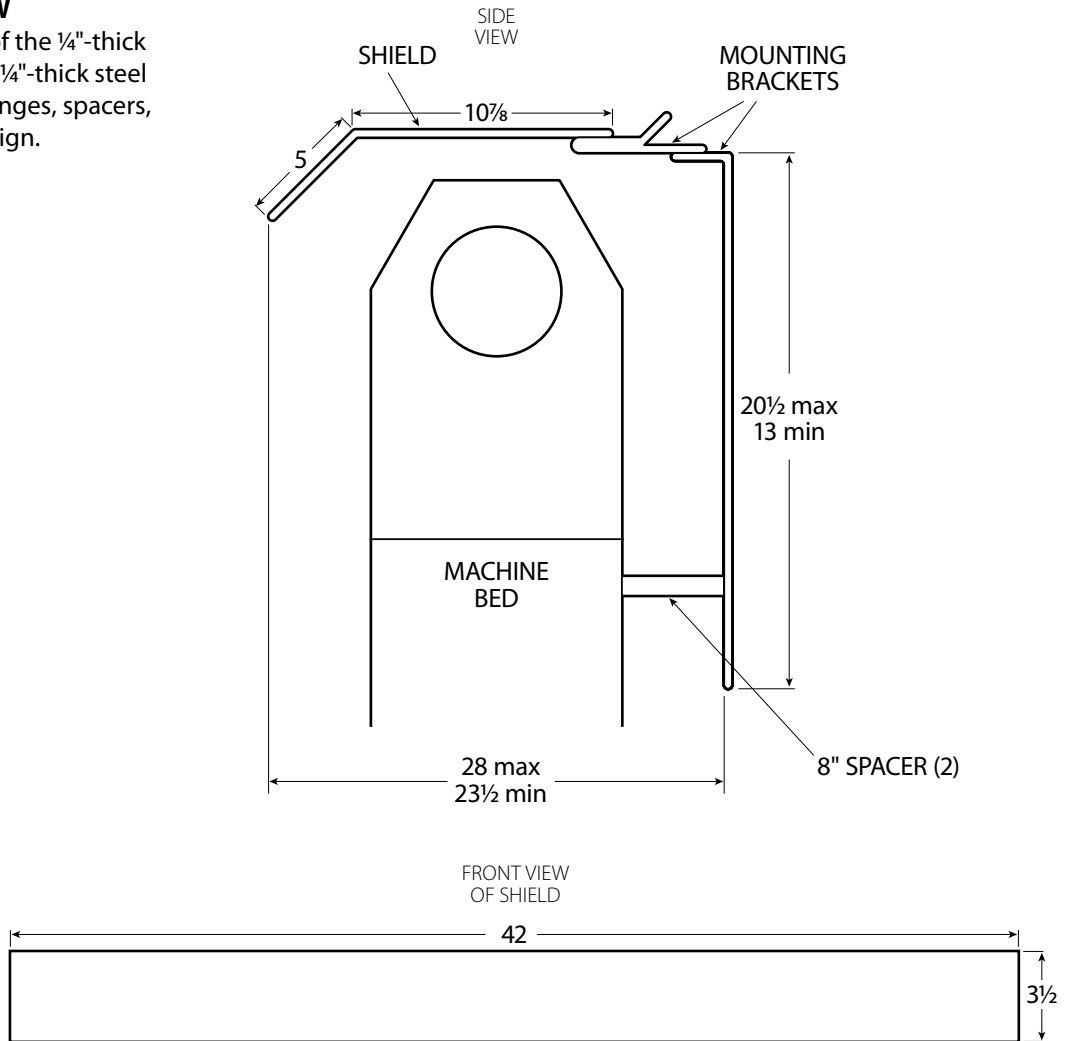

Optional Rear Shields

To safeguard individuals at the backside of the lathe, the following shields are available:

Part No. SHD-924LWR

Assembly consisting of the 3/16"-thick polycarbonate shield and fasteners. (Attaches to SHD-1024LW shield upright bracket.)

Price: \$71.00

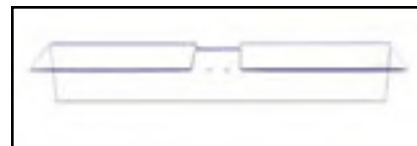

Part No. SHD-2042LWR

Assembly consisting of the 1/4"-thick polycarbonate shield and fasteners. (Attaches to above SHD-1642LW shield upright bracket.)

Price: \$182.00

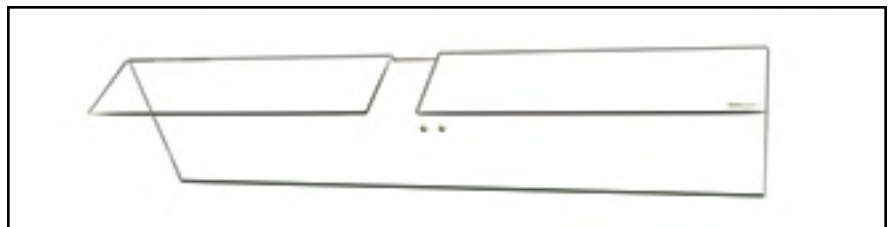

Portable Shields



for Mills, Drills, Lathes, Etc.



Storage Hook

SHD-2315MP portable shield being used and stored on a milling machine.

These $\frac{3}{16}$ "-thick polycarbonate portable shields can be used on mills, drills, lathes, and any other machines that need a handheld or attached shield to protect individuals. The two shields shown on this page are furnished with two

$\frac{1}{2}$ "-13 x 1" long button-head cap screws for attaching the shield to a 6" vise (most 6" vises have two $\frac{1}{2}$ "-13 holes on $\frac{3}{8}$ " centers). The shield can be stored on the machine, a wall, or a post by hanging the shield on the hook provided.

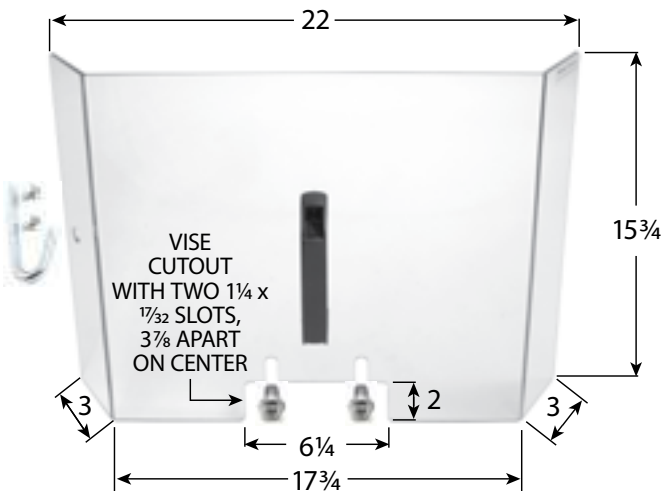

Part No. SHD-2315MP

Assembly consisting of the shield with 3" wings, handle, two $\frac{1}{2}$ "-13 x 1" L button-head cap screws, storage hook with fasteners, and safety sign. Price: \$129.00

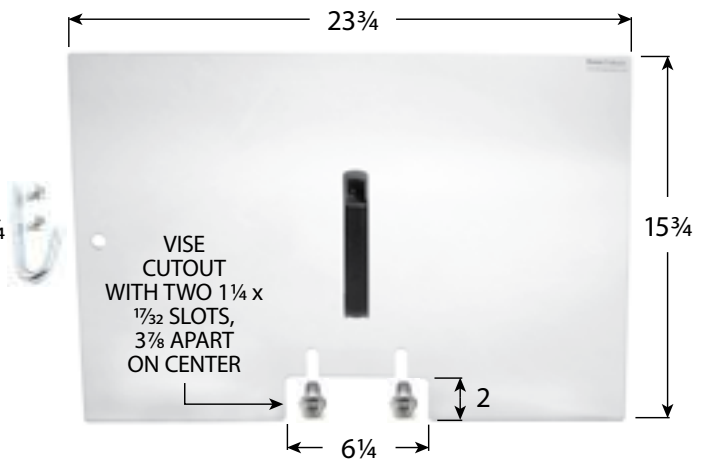

Part No. SHD-2315MFP

Assembly consisting of the shield, handle, two $\frac{1}{2}$ "-13 x 1" L button-head cap screws, storage hook with fasteners, and safety sign. Price: \$98.00

Portable Shields



for Mills, Drills, Lathes, Etc.

These $\frac{3}{16}$ "-thick polycarbonate flat portable shields can be used on mills, drills, lathes, and any other machines that need a handheld shield to protect individuals. These assemblies consist of the shield, handle, storage hook with fasteners, and safety sign.

Part No. SHD-1512FP

15 $\frac{3}{4}$ " W x 12 $\frac{3}{4}$ " H.

Price: \$65.00

Part No. SHD-2315FP

23 $\frac{3}{4}$ " W x 15 $\frac{3}{4}$ " H.

Price: \$73.00



SHD-1512FP portable shield being used on a milling machine.

Free-Standing Shields

These free-standing shields can be used in many applications for safeguarding as well as for housekeeping. Ideal for lathes and milling machines, these shields can be applied between machines, on the backside of machines, and along aisles. They can also be used in other applications to protect individuals from flying chips, sparks, coolant, lubricant, and other particles.

These assemblies are constructed of 1 $\frac{1}{2}$ "-square extruded aluminum with a 48" W x 36" H x $\frac{1}{4}$ "-thick polycarbonate panel and include fasteners and a safety sign. The shield can be adjusted up or down on the posts. Custom sizes are available upon request.

Part No. SHD-4836FS

Assembly with stationary glide feet.

Price: \$862.00

Part No. SHD-4836FSLC

Assembly with locking swivel casters.

Price: \$981.00

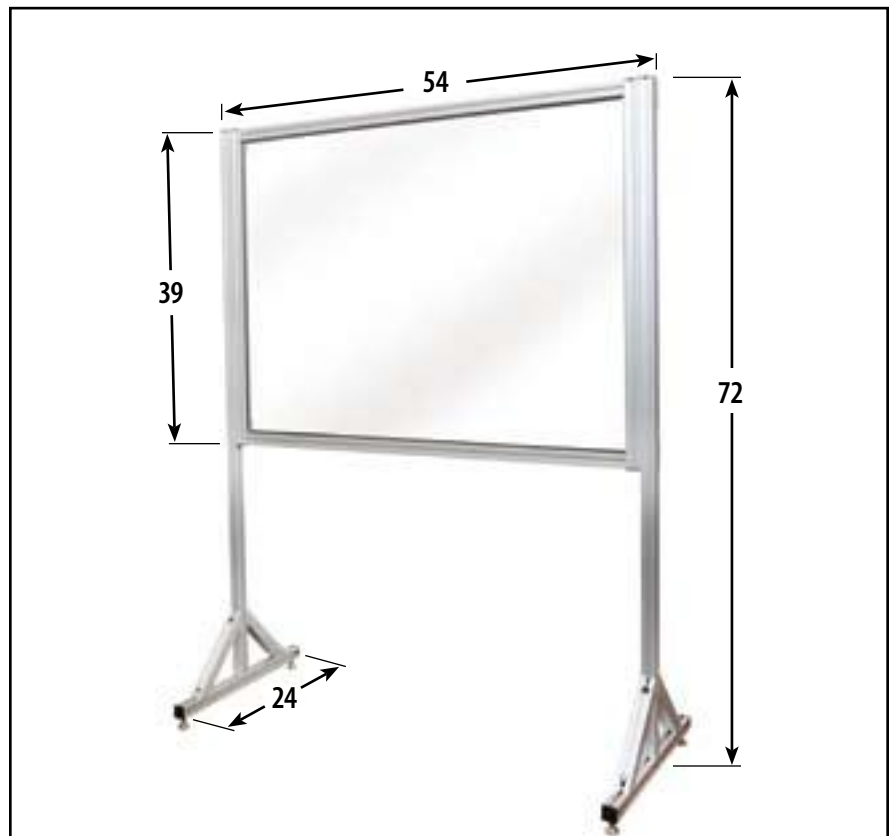

Snake-Arm Shields



Each shield assembly below consists of a shield, shield bracket, heavy-duty snake arm with attached direct-mount base, and safety sign. Ideal for bench grinders, drills, small mills, etc.

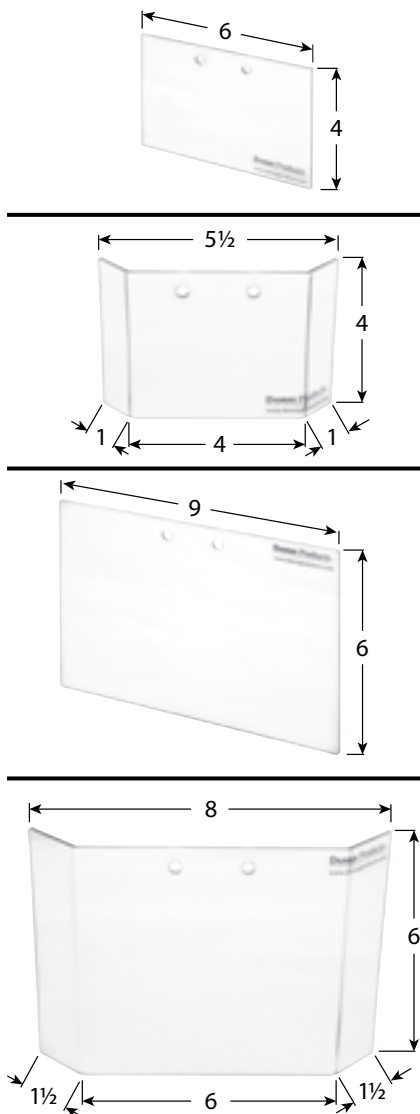

Shield Assembly Part Number	Description	Arm Length	Price
SHD-864F	6" W x 4" H Flat, 3/16" Thick	8"	\$51.17
SHD-1264F	6" W x 4" H Flat, 3/16" Thick	12"	62.79
SHD-1864F	6" W x 4" H Flat, 3/16" Thick	18"	63.91
SHD-2164F	6" W x 4" H Flat, 3/16" Thick	21"	65.91
SHD-2464F	6" W x 4" H Flat, 3/16" Thick	24"	68.81
SHD-864W	1" Wings on 45° Angles, 3/16" Thick	8"	54.45
SHD-1264W	1" Wings on 45° Angles, 3/16" Thick	12"	66.07
SHD-1864W	1" Wings on 45° Angles, 3/16" Thick	18"	67.19
SHD-2164W	1" Wings on 45° Angles, 3/16" Thick	21"	69.19
SHD-2464W	1" Wings on 45° Angles, 3/16" Thick	24"	72.09
SHD-896F	9" W x 6" H Flat, 3/16" Thick	8"	52.69
SHD-1296F	9" W x 6" H Flat, 3/16" Thick	12"	64.31
SHD-1896F	9" W x 6" H Flat, 3/16" Thick	18"	65.43
SHD-2196F	9" W x 6" H Flat, 3/16" Thick	21"	67.43
SHD-2496F	9" W x 6" H Flat, 3/16" Thick	24"	70.33
SHD-896W	1 1/2" Wings on 45° Angles, 3/16" Thick	8"	55.97
SHD-1296W	1 1/2" Wings on 45° Angles, 3/16" Thick	12"	67.59
SHD-1896W	1 1/2" Wings on 45° Angles, 3/16" Thick	18"	68.71
SHD-2196W	1 1/2" Wings on 45° Angles, 3/16" Thick	21"	70.71
SHD-2496W	1 1/2" Wings on 45° Angles, 3/16" Thick	24"	73.61

The shield assemblies above include a heavy-duty snake-arm with a 2" x 1" attached direct-mount base that comes with two 1/4"-20 socket-head cap screws, two 1/4"-20 locknuts, and two No. 12 sheet-metal screws. The following *optional* bases or brackets can be added to the direct-mount base.



SHD-1896F shield assembly with an optional MAG-100 magnetic base.



MAG-100 Magnetic Base

Part No. MAG-100*
Magnetic base assembly has a 3/4"-diameter magnet with 100 pounds of holding force.
Price: \$18.02



CMP-200 C-Clamp Base

Part No. CMP-200
C-clamp base assembly for mounting to the edge of a surface up to 1/8" thick. **Price: \$18.02**



BKT-150 Horizontal Mounting Bracket

Part No. BKT-150
Horizontal right-angle mounting bracket assembly. **Price: \$14.25**



BKT-160 Vertical Mounting Bracket

Part No. BKT-160
Vertical right-angle mounting bracket assembly. **Price: \$14.25**

*When applying a magnetic base, the mounting surface must be flat, ferrous metal thick enough and with a high percentage of iron for good holding power.

Snake-Arm Shields



Each shield assembly below consists of a shield, shield bracket, heavy-duty snake arm with attached direct-mount base, and safety sign. Ideal for grinders, drills, mills, etc.

Shield Assembly Part Number	Description	Arm Length	Price
SHD-8165F	16" W x 5" H Flat, 3/16" Thick	8"	\$60.35
SHD-12165F	16" W x 5" H Flat, 3/16" Thick	12"	71.97
SHD-18165F	16" W x 5" H Flat, 3/16" Thick	18"	73.09
SHD-21165F	16" W x 5" H Flat, 3/16" Thick	21"	75.09
SHD-24165F	16" W x 5" H Flat, 3/16" Thick	24"	77.99
SHD-8107F	10" W x 7" H Flat, 3/16" Thick	8"	56.52
SHD-12107F	10" W x 7" H Flat, 3/16" Thick	12"	68.14
SHD-18107F	10" W x 7" H Flat, 3/16" Thick	18"	69.26
SHD-21107F	10" W x 7" H Flat, 3/16" Thick	21"	71.26
SHD-24107F	10" W x 7" H Flat, 3/16" Thick	24"	74.16
SHD-30107F	10" W x 7" H Flat, 3/16" Thick	30"	76.46
SHD-8107W	2" Wings on 45° Angles, 3/16" Thick	8"	59.80
SHD-12107W	2" Wings on 45° Angles, 3/16" Thick	12"	71.42
SHD-18107W	2" Wings on 45° Angles, 3/16" Thick	18"	72.54
SHD-21107W	2" Wings on 45° Angles, 3/16" Thick	21"	74.54
SHD-24107W	2" Wings on 45° Angles, 3/16" Thick	24"	77.44
SHD-30107W	2" Wings on 45° Angles, 3/16" Thick	30"	79.74

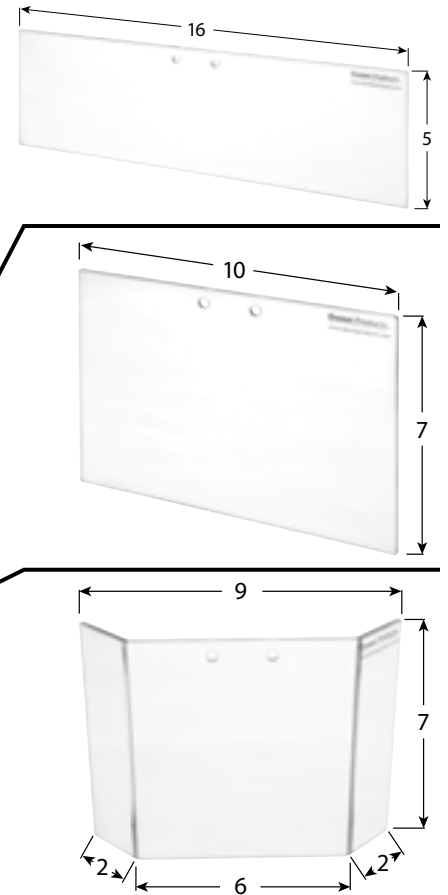

The shield assemblies above include a heavy-duty snake-arm with a 2" x 1" attached direct-mount base that comes with two 1/4"-20 socket-head cap screws, two 1/4"-20 locknuts, and two No. 12 sheet-metal screws. The following *optional* bases or brackets can be added to the direct-mount base.



Part No. MAG-100*
Magnetic base assembly has a 3/4"-diameter magnet with 100 pounds of holding force. **Price: \$18.02**



Part No. CMP-200
C-clamp base assembly for mounting to the edge of a surface up to 1 7/8" thick. **Price: \$18.02**



Part No. BKT-150
Horizontal right-angle mounting bracket assembly. **Price: \$14.25**



Part No. BKT-160
Vertical right-angle mounting bracket assembly. **Price: \$14.25**



SHD-12165F shield assembly on a pedestal grinder.

*When applying a magnetic base, the mounting surface must be flat, ferrous metal thick enough and with a high percentage of iron for good holding power.

Snake-Arm Shields



Each shield assembly below consists of a shield, two shield brackets, two heavy-duty snake arms with attached direct-mount bases, and safety sign. Ideal for surface grinders.

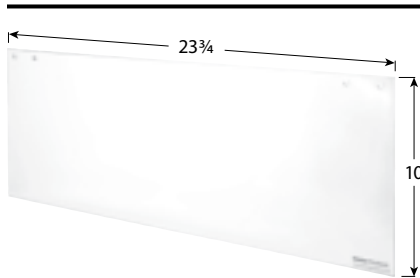
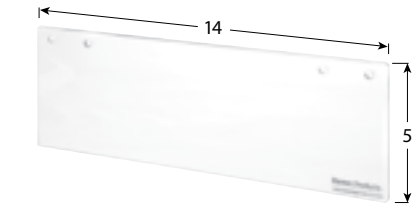

Shield Assembly Part Number	Description	Length of Both Arms	Price
SHD-8145F	14" W x 5" H Flat With Two Arms, 3/16" Thick	8"	\$ 95.66
SHD-12145F	14" W x 5" H Flat With Two Arms, 3/16" Thick	12"	118.90
SHD-18145F	14" W x 5" H Flat With Two Arms, 3/16" Thick	18"	121.14
SHD-21145F	14" W x 5" H Flat With Two Arms, 3/16" Thick	21"	125.14
SHD-24145F	14" W x 5" H Flat With Two Arms, 3/16" Thick	24"	130.94
SHD-30145F	14" W x 5" H Flat With Two Arms, 3/16" Thick	30"	135.54
SHD-36145F	14" W x 5" H Flat With Two Arms, 3/16" Thick	36"	142.50
SHD-8188F	18" W x 8" H Flat With Two Arms, 3/16" Thick	8"	105.80
SHD-12188F	18" W x 8" H Flat With Two Arms, 3/16" Thick	12"	129.04
SHD-18188F	18" W x 8" H Flat With Two Arms, 3/16" Thick	18"	131.28
SHD-21188F	18" W x 8" H Flat With Two Arms, 3/16" Thick	21"	135.28
SHD-24188F	18" W x 8" H Flat With Two Arms, 3/16" Thick	24"	141.08
SHD-30188F	18" W x 8" H Flat With Two Arms, 3/16" Thick	30"	145.68
SHD-36188F	18" W x 8" H Flat With Two Arms, 3/16" Thick	36"	152.64
SHD-82310F	23 3/4" W x 10" H Flat With Two Arms, 3/16" Thick	8"	114.53
SHD-122310F	23 3/4" W x 10" H Flat With Two Arms, 3/16" Thick	12"	137.77
SHD-182310F	23 3/4" W x 10" H Flat With Two Arms, 3/16" Thick	18"	140.01
SHD-212310F	23 3/4" W x 10" H Flat With Two Arms, 3/16" Thick	21"	144.01
SHD-242310F	23 3/4" W x 10" H Flat With Two Arms, 3/16" Thick	24"	149.81
SHD-302310F	23 3/4" W x 10" H Flat With Two Arms, 3/16" Thick	30"	154.41
SHD-362310F	23 3/4" W x 10" H Flat With Two Arms, 3/16" Thick	36"	161.37

The shield assemblies above include two heavy-duty snake-arm assemblies with a 2" x 1" attached direct-mount base that comes with two 1/4"-20 socket-head cap screws, two 1/4"-20 locknuts, and two No. 12 sheet-metal screws. The following *optional* bases or brackets can be added to each direct-mount base.



SHD-24188F shield assembly with two optional BKT-150 mounting brackets on a surface grinder.



MAG-100 Magnetic Base

Part No. MAG-100*

Magnetic base assembly has a 3 3/4"-diameter magnet with 100 pounds of holding force. Price: \$18.02

Part No. CMP-200

C-clamp base assembly for mounting to the edge of a surface up to 1 7/8" thick. Price: \$18.02



CMP-200 C-Clamp Base



BKT-150 Horizontal Mounting Bracket

Part No. BKT-150

Horizontal right-angle mounting bracket assembly. Price: \$14.25

Part No. BKT-160

Vertical right-angle mounting bracket assembly. Price: \$14.25



BKT-160 Vertical Mounting Bracket

*When applying a magnetic base, the mounting surface must be flat, ferrous metal thick enough and with a high percentage of iron for good holding power.

Snake-Arm Shields



Each shield assembly below consists of a shield, shield bracket with handle, heavy-duty snake arm with attached direct-mount base, and safety sign. Ideal for drills, mills, etc.

Shield Assembly Part Number	Description	Arm Length	Price
SHD-81412F	14" W x 11 ³ / ₄ " H Flat, ³ / ₁₆ " Thick	8"	\$ 87.58
SHD-121412F	14" W x 11 ³ / ₄ " H Flat, ³ / ₁₆ " Thick	12"	99.20
SHD-181412F	14" W x 11 ³ / ₄ " H Flat, ³ / ₁₆ " Thick	18"	100.32
SHD-211412F	14" W x 11 ³ / ₄ " H Flat, ³ / ₁₆ " Thick	21"	102.32
SHD-241412F	14" W x 11 ³ / ₄ " H Flat, ³ / ₁₆ " Thick	24"	105.22
SHD-8169W	3" Wings on 45° Angles, ³ / ₁₆ " Thick	8"	89.95
SHD-12169W	3" Wings on 45° Angles, ³ / ₁₆ " Thick	12"	101.57
SHD-18169W	3" Wings on 45° Angles, ³ / ₁₆ " Thick	18"	102.69
SHD-21169W	3" Wings on 45° Angles, ³ / ₁₆ " Thick	21"	104.69
SHD-24169W	3" Wings on 45° Angles, ³ / ₁₆ " Thick	24"	107.59
SHD-8169U	U-Shaped on 90° Angles, ³ / ₁₆ " Thick	8"	89.95
SHD-12169U	U-Shaped on 90° Angles, ³ / ₁₆ " Thick	12"	101.57
SHD-18169U	U-Shaped on 90° Angles, ³ / ₁₆ " Thick	18"	102.69
SHD-21169U	U-Shaped on 90° Angles, ³ / ₁₆ " Thick	21"	104.69
SHD-24169U	U-Shaped on 90° Angles, ³ / ₁₆ " Thick	24"	107.59

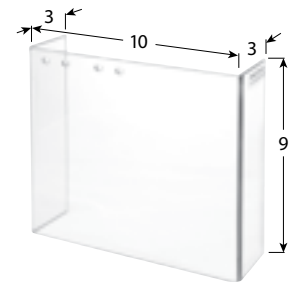
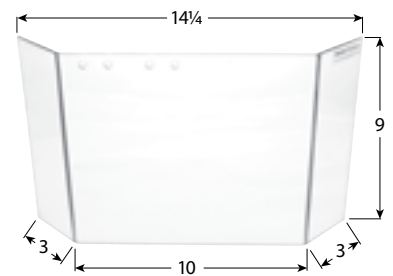
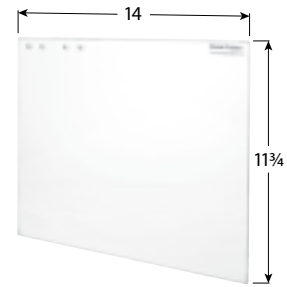

The shield assemblies above include a heavy-duty snake-arm with a 2" x 1" attached direct-mount base that comes with two 1/4"-20 socket-head cap screws, two 1/4"-20 locknuts, and two No. 12 sheet-metal screws. The following *optional* bases or brackets can be added to the direct-mount base.



MAG-100 Magnetic Base

Part No. MAG-100*
Magnetic base assembly has a 3³/₄"-diameter magnet with 100 pounds of holding force. Price: \$18.02



CMP-200 C-Clamp Base

Part No. CMP-200
C-clamp base assembly for mounting to the edge of a surface up to 1⁷/₈" thick. Price: \$18.02



BKT-150 Horizontal Mounting Bracket

Part No. BKT-150
Horizontal right-angle mounting bracket assembly. Price: \$14.25



BKT-160 Vertical Mounting Bracket

Part No. BKT-160
Vertical right-angle mounting bracket assembly. Price: \$14.25



SHD-12169U shield assembly with an optional BKT-150 mounting bracket on a milling machine.

*When applying a magnetic base, the mounting surface must be flat, ferrous metal thick enough and with a high percentage of iron for good holding power.

Snake-Arm Shields

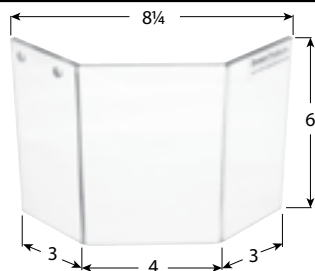
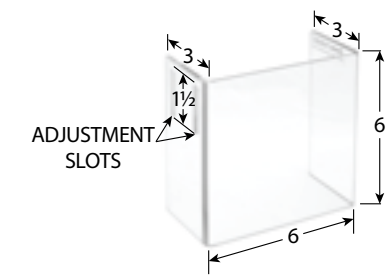
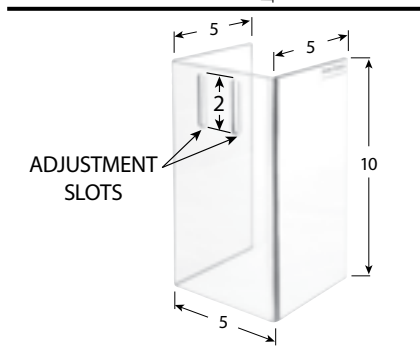
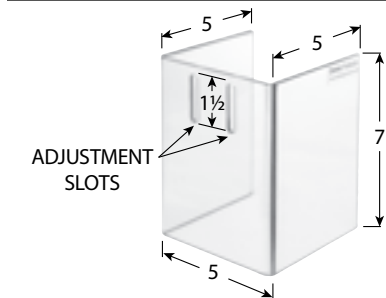

Each shield assembly below consists of a shield, shield bracket, heavy-duty snake arm with attached direct-mount base, and safety sign. Ideal for vertical band saws, drills, mills, etc.

Part Number	Description	Arm Length	Price
SHD-8157U	U-Shaped on 90° Angles, 3/16" Thick	8"	\$ 74.92
SHD-12157U	U-Shaped on 90° Angles, 3/16" Thick	12"	86.54
SHD-18157U	U-Shaped on 90° Angles, 3/16" Thick	18"	87.66
SHD-21157U	U-Shaped on 90° Angles, 3/16" Thick	21"	89.66
SHD-24157U	U-Shaped on 90° Angles, 3/16" Thick	24"	92.56
SHD-81510U	U-Shaped on 90° Angles, 3/16" Thick	8"	77.10
SHD-121510U	U-Shaped on 90° Angles, 3/16" Thick	12"	88.72
SHD-181510U	U-Shaped on 90° Angles, 3/16" Thick	18"	89.84
SHD-211510U	U-Shaped on 90° Angles, 3/16" Thick	21"	91.84
SHD-241510U	U-Shaped on 90° Angles, 3/16" Thick	24"	94.74
SHD-8126U	U-Shaped on 90° Angles, 3/16" Thick	8"	72.71
SHD-12126U	U-Shaped on 90° Angles, 3/16" Thick	12"	84.33
SHD-18126U	U-Shaped on 90° Angles, 3/16" Thick	18"	85.45
SHD-21126U	U-Shaped on 90° Angles, 3/16" Thick	21"	87.45
SHD-24126U	U-Shaped on 90° Angles, 3/16" Thick	24"	90.35
SHD-8106W	3" Wings on 45° Angles, 3/16" Thick	8"	58.67
SHD-12106W	3" Wings on 45° Angles, 3/16" Thick	12"	70.29
SHD-18106W	3" Wings on 45° Angles, 3/16" Thick	18"	71.41
SHD-21106W	3" Wings on 45° Angles, 3/16" Thick	21"	73.41
SHD-24106W	3" Wings on 45° Angles, 3/16" Thick	24"	76.31

The shield assemblies above include a heavy-duty snake-arm with a 2" x 1" attached direct-mount base that comes with two 1/4"-20 socket-head cap screws, two 1/4"-20 locknuts, and two No. 12 sheet-metal screws. The following *optional* bases or brackets can be added to the direct-mount base.

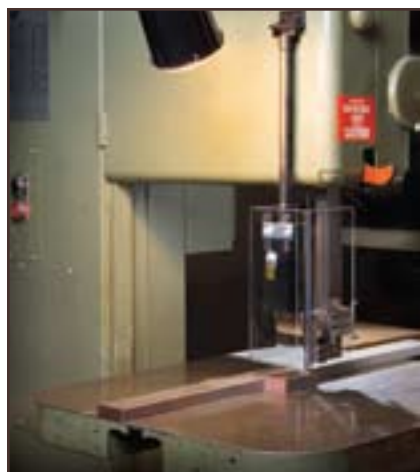

SHD-121510U shield assembly with an optional BKT-150 mounting bracket on a vertical band saw.



Part No. MAG-100*
Magnetic base assembly has a 3 3/4"-diameter magnet with 100 pounds of holding force. Price: \$18.02



Part No. CMP-200
C-clamp base assembly for mounting to the edge of a surface up to 1 7/8" thick. Price: \$18.02



Part No. BKT-150
Horizontal right-angle mounting bracket assembly. Price: \$14.25



Part No. BKT-160
Vertical right-angle mounting bracket assembly. Price: \$14.25

*When applying a magnetic base, the mounting surface must be flat, ferrous metal thick enough and with a high percentage of iron for good holding power.

Individual/Replacement Snake-Arm Shield Parts

Individual/Replacement Heavy-Duty Snake-Arm Assemblies

- 8"  Part No. ARM-008 Assembly. Max Holding Weight: 48 oz. Price: **\$32.02**
- 12"  Part No. ARM-012 Assembly. Max Holding Weight: 48 oz. Price: **\$43.64**
- 18"  Part No. ARM-018 Assembly. Max Holding Weight: 40 oz. Price: **\$44.76**
- 21"  Part No. ARM-021 Assembly. Max Holding Weight: 35 oz. Price: **\$46.76**
- 24"  Part No. ARM-024 Assembly. Max Holding Weight: 32 oz. Price: **\$49.66**
- 30"  Part No. ARM-030 Assembly. Max Holding Weight: 20 oz. Price: **\$51.96**
- 36"  Part No. ARM-036 Assembly. Max Holding Weight: 17 oz. Price: **\$55.44**



Each heavy-duty snake-arm assembly consists of one heavy-duty snake arm and the mounting hardware shown above.



Part No. BKT-120 Shield Bracket Assembly
(for Snake-Arm Shields on Pages 30–32, 34)
Price: **\$3.85**



Part No. BKT-140 Shield Bracket Assembly
(for Snake-Arm Shields on Page 33)
Price: **\$17.53**

Individual/Replacement Shields

Part Number	Description	Weight	Reference Page in This Catalog	Price
RSO-64F	6" W x 4" H Flat, 3/16" Thick	5.4 oz	30	\$15.30
RSO-64W	1" Wings on 45° Angles, 3/16" Thick	5.4 oz	30	18.58
RSO-96F	9" W x 6" H Flat, 3/16" Thick	9.1 oz	30	16.82
RSO-96W	1½" Wings on 45° Angles, 3/16" Thick	9.1 oz	30	20.10
RSO-106W	3" Wings on 45° Angles, 3/16" Thick	9.9 oz	34	22.80
RSO-107F	10" W x 7" H Flat, 3/16" Thick	10.9 oz	31	20.65
RSO-107W	2" Wings on 45° Angles, 3/16" Thick	10.9 oz	31	23.93
RSO-145F	14" W x 5" H Flat, 3/16" Thick	13.7 oz	32	23.92
RSO-126U	U-Shaped on 90° Angles, 3/16" Thick	10.5 oz	34	36.84
RSO-165F	16" W x 5" H Flat, 3/16" Thick	12.9 oz	31	24.48
RSO-157U	U-Shaped on 90° Angles, 3/16" Thick	14.6 oz	34	39.05
RSO-188F	18" W x 8" H Flat, 3/16" Thick	22.8 oz	32	34.06
RSO-169W	3" Wings on 45° Angles, 3/16" Thick	23.0 oz	33	40.40
RSO-169U	U-Shaped on 90° Angles, 3/16" Thick	23.0 oz	33	40.40
RSO-1510U	U-Shaped on 90° Angles, 3/16" Thick	20.1 oz	34	41.23
RSO-1412F	14" W x 11¾" H Flat, 3/16" Thick	26.0 oz	33	38.03
RSO-2310F	23¾" W x 10" H Flat, 3/16" Thick	34.9 oz	32	42.79

Snake-Arm Lamps



According to several ANSI B11-series safety standards for machine tools (such as ANSI B11.8 for milling, drilling, and boring machines and ANSI B11.6 for lathes), lighting must be installed to ensure that personnel can safely perform their tasks. For lighting requirements, the ANSI B11-series standards reference the ANSI/IESNA RP-7 standard, *Recommended Practice for Lighting Industrial Facilities*. (IESNA is the Illuminating Engineering Society of North America.)

To help industrial users meet applicable ANSI B11-series safety standards as well as the ANSI/IESNA RP-7 standard for lighting requirements, we offer snake-arm lamps that will light the point of operation of machines or work areas where additional light is required. A bright, conical metal reflector directs the light to where it is needed. Each lamp uses a 100-watt-maximum standard incandescent or equivalent (CFL, LED) screw-in lightbulb (not included). An innovative, finned-aluminum heat sink keeps the on/off toggle switch cool for a long switch life. The heavy-duty snake arms are made of spring steel covered with vinyl to protect them from grease, oil, and contaminants that would weaken their holding ability (unlike other inferior gooseneck or flexible arms found on the market). They offer practically unlimited adjustment possibilities and long-term holding power.

All snake-arm lamps are UL Listed to United States and Canadian safety standards. Each lamp has a 6' oil-resistant power cord with a 120-volt grounded plug. The SJTO 18/3 thermoplastic cord has three 18-gauge wires, a NEMA 5-15 plug, and is rated up to 105°C (221°F). Each lampshade

is made of high-impact polycarbonate that is resistant to chipping, denting, and cracking. The lampshade has a double wall that keeps the outer wall from getting too hot; this allows adjustment of the lampshade while in use, even after the lamp has been on for hours!

Three different mounting bases are available: direct-mount, C-clamp, and magnetic. The direct-mount base can be fastened to most any flat surface at least 2" x 1" with two included ¼" fasteners. The C-clamp base can be mounted to the edge of a table, bench, or any surface up to 1⅞" thick. The magnetic base has a 3¼"-diameter magnet with 100 pounds of holding force. (Note: When applying a magnetic base, the mounting surface must be flat, ferrous metal thick enough and with a high percentage of iron for good holding power.)

Optional accessories include a wire guard that can be snapped onto the front rim of the lampshade to protect the lightbulb, two magnifier attachments that can mount directly to the lampshade, and two right-angle mounting brackets. Both magnifier attachments have a 2" x 4", 2-power glass lens, but one also includes a 1"-diameter, 4-power meniscus inset located near the right edge of the lens. Each magnifier attachment comes with a cover that slides over the lens to protect it when not in use. (Note: A wire guard cannot be used in conjunction with a magnifier attachment.) Based on the available mounting location(s), a horizontal or vertical right-angle mounting bracket can be used with the direct-mount base to help position the lamp where needed.

Snake-Arm Lamps



Part No. LMP-18D
18" Direct-Mount-Base Lamp



Close-Up of Direct-Mount Base
(Showing Included Fasteners)



LMP-24M lamp with an optional LMP-WG wire guard being used on a lathe.



Part No. LMP-24C
24" C-Clamp-Base Lamp



Close-Up of C-Clamp Base



LMP-24C mounted on a drafting table.



Part No. LMP-18M
18" Magnetic-Base Lamp



Close-Up of Magnetic Base



Optional Part No. LMP-WG Wire
Guard Snapped Onto Lampshade



Optional Part No. LMP-MA
Magnifier Attached to Lampshade



Optional Part No. BKT-150
Horizontal Mounting Bracket Assembly



Optional Part No. BKT-160
Vertical Mounting Bracket Assembly

Part No.	Snake-Arm Lamp Description	Price
LMP-18D	Lamp With 18" Snake Arm and Direct-Mount Base	\$67.12
LMP-24D	Lamp With 24" Snake Arm and Direct-Mount Base	70.84
LMP-18C	Lamp With 18" Snake Arm and C-Clamp Base	79.60
LMP-24C	Lamp With 24" Snake Arm and C-Clamp Base	85.16
LMP-18M	Lamp With 18" Snake Arm and Magnetic Base	79.60
LMP-24M	Lamp With 24" Snake Arm and Magnetic Base	85.16

Part No.	Optional Accessory Description	Price
LMP-WG	Wire Guard That Snaps Onto the Lampshade to Protect the Bulb	\$ 6.20
LMP-MA	Magnifier Attachment With 2" x 4", 2-Power Glass Lens	37.14
LMP-MAD	Magnifier Attachment With 2" x 4", 2-Power Glass Lens and 4-Power Inset	45.96
BKT-150	Horizontal Right-Angle Mounting Bracket Assembly	14.25
BKT-160	Vertical Right-Angle Mounting Bracket Assembly	14.25

About Our Safety Products

Shields Overview

The shields offered in this catalog are designed to apply to a wide variety of machinery and equipment that need safeguarding. The shields have the ability to be moved easily in and out of the safeguarded position for tool changes or they can be readjusted to fit various machine applications.

Our machine safety shields serve two basic functions: (1) they provide a safeguard between individuals and point-of-operation or moving hazards, and (2) they protect individuals from flying chips, sparks, coolant, lubricant, and other particles.

The shields are made of 3/16"- or 1/4"-thick (0.177" or 0.236" ± 5%) polished, UV-stabilized polycarbonate. They are virtually unbreakable with 250 times the impact strength of float glass and 30 times that of acrylic.

When determining the shield size, measure the length and height of the area that the shield will be safeguarding. In addition, determine what type shield will be most appropriate for the particular application. If a snake-arm shield will be used, also measure the length of the arm needed. Several standard sizes and shapes of shields are available to fit many applications and machine types, but custom shield sizes and shapes are available. Please contact us if you have a custom requirement for shields or arms.

The following machines are just a few examples of the types of machines that our shields can be applied to.

Metalworking

Lathes (engine, turret, vertical turret)
Milling machines (vertical, horizontal)
Drilling machines (drill presses, gang drills, radial drills)
Grinders (bench/pedestal, surface, jig, rotary, OD, ID)
Vertical band saws

Woodworking

Wood lathes
Drilling machines (drill presses, gang drills)
Vertical band saws

• Lathes

Lathes usually have two areas of consideration when safeguarding: (1) the rotating chuck, and (2) the area where the tooling comes into contact with the workpiece. Both areas need to be safeguarded. Various shields offered in this catalog can be applied to lathes.

• Milling and Drilling Machines

Milling and drilling machines present a safety hazard from the flying chips and coolant generated at the point of operation by the tool and workpiece. Various shields offered in this catalog can be applied to milling and drilling machines.

• Grinders

There are a variety of grinding machines being used in industry today (bench/pedestal, surface, rotary, OD, ID). Grinding wheels produce sparks, chips, and other particles that create a hazard to individuals. Various shields offered in this catalog can be applied to grinding machines.

• Vertical Band Saws

The band saw blade creates the hazard on these machines. The U-shaped shields on page 34 can be applied to vertical band saws.

Our shields can also be applied to packaging machines, textile machinery, food-processing equipment, and many other applications.

Snake Arms

Our snake arms hold a shield or lamp in the position where it is needed. They offer practically unlimited adjustment possibilities and long-term holding power. These **heavy-duty** arms are made of spring steel that is covered with vinyl to protect them from grease, oil, and contaminants that would weaken their holding ability. And the snake arms used with our shields are specifically designed for shield applications, so they are more heavy-duty and can hold more weight than the snake arms used with our lamps.

When determining the arm length, measure between the mounting location and where the shield or lamp will be used. The snake arms are available in various standard lengths, but custom lengths are available. Please contact us if you have a custom requirement.

Safety Standards

The Occupational Safety and Health Administration (OSHA) requires in 29 CFR 1910.212 that one or more methods of machine safeguarding be provided to protect the operator and other employees in the machine area from hazards such as those created by the point of operation, rotating parts, flying chips, and sparks.

Other applicable OSHA standards for metalworking and woodworking machinery are 29 CFR 1910.213 for woodworking machinery, 29 CFR 1910.215 for abrasive wheel machinery (grinders), and 29 CFR 1910.219 for mechanical power-transmission apparatuses such as belts, shafts, and pulleys.

In the absence of applicable specific OSHA standards, the American National Standards Institute (ANSI) has a comprehensive, up-to-date series of standards that should be referenced. These standards are the ANSI B11 series of standards for safety on metalworking machines. This series includes specific standards such as B11.6 for manual turning machines (lathes) with or without automatic control, B11.8 for manual milling, drilling, and boring machines with or without automatic control, B11.9 for grinding machines, and B11.10 for metal-sawing machines. For safety requirements on woodworking machinery, the applicable ANSI standard is ANSI O1.1.

In addition to safeguarding, other applicable safety standards and requirements must be considered, including electrical requirements, mechanical power-transmission apparatuses, personal protective equipment, and the control of hazardous energy (lockout/tagout).

Other Applications

The shields offered in this catalog can be applied to many metalworking and woodworking machines, as mentioned previously, but there are many other applications not mentioned in the catalog in which our shields can be used. In addition, the lamps can be used in countless other applications such as lighting workbenches, tables, desks, and office workspaces—the possibilities are almost endless!

Quality

The shields and other products offered in this catalog have been designed and constructed with the highest quality for flexibility of use and long life. Each product is inspected for quality during and after manufacturing to ensure a well-built and durable product. We believe in total quality management (TQM) and strive for zero defects through continual improvement in our operations.

New Products

New machine safeguards and accessories are frequently being developed and introduced. Please check our website at www.danrayproducts.com to stay up to date.

Terms and Conditions of Sale

Prices

Prices are as indicated and are in U.S. dollars. Prices specified do not include any shipping and handling charges, nor do they include any federal, state, local, use, occupation, foreign, or other taxes. These additional charges, if applicable, will be added to the order during the checkout process (for online orders) or to the invoice (for purchase orders).

Open-Account Credit Policy

Customers may order by purchase order only after credit approval. New customers must apply for an open account by submitting credit references and bank information to us by fax or by e-mail. Purchase orders received without suitable credit information will not be processed until adequate information has been received and credit has been approved.

Customers that are not approved for an open account must prepay each order in full before the order is processed and shipped. For faster service, orders can be placed through our online store and paid for via credit card.

Payment Terms and Accepted Methods of Payment

Online orders must be paid in full at the time of order with Visa, MasterCard, American Express, or Discover. SSL (Secure Sockets Layer) software protects all payment information that you enter on our website by encrypting it during transmission.

Purchase orders must be paid in full no more than 30 days from the date of invoice (Net 30). Past-due accounts will incur a 1½% monthly service charge (18% a year) and will be placed on hold until the past-due balance is paid.

Delivery

Most products are in stock or will ship within one week. We will notify customers with the expected ship date for products that will not ship within one week.

Shipping and Handling

Online orders will be shipped via UPS with the service type selected during checkout. A shipping and handling charge will automatically be added to all orders during the online checkout process (except for shipments being billed to the receiver).

Purchase orders will normally be shipped prepaid via our carrier of choice with the charges added to the invoice, but they may also be billed to the receiver or a third party. Please note that a handling charge of up to \$5.00 will be added to all invoices (except for shipments billed to the receiver or a third party).

Insurance

Online orders will automatically be insured for the standard amount provided by UPS.

Purchase orders will be insured for the standard amount provided by the carrier, but additional insurance may be purchased at the customer's expense.

Risk of Loss

Unless otherwise agreed upon, all orders will be shipped FOB shipping point. This means that the title and risk of loss for orders will pass to the customer upon delivery to the carrier at the point of shipment. Therefore, the customer will be responsible for making any and all claims directly against the carrier for loss or damage during shipment.

Returns

Danray Products LLC must authorize all returns in advance, at which time an RMA (return materials authorization) number will be given to the customer. No returns will be accepted unless accompanied by an RMA number and this RMA number plainly identified on the outside of the package. Our receiving department will refuse returns without an RMA number. Shipping charges for all returns must be prepaid. The minimum restocking charge will be 25% for any product(s) returned for credit. Such product(s) must be in original condition and unused in order to qualify for credit. No returns for credit will be considered more than 30 days from the date of shipment.

Warranty

Danray Products LLC warrants that our products will be free from defects in material and workmanship for a period of 12 months from the date of shipment. DANRAY PRODUCTS LLC'S OBLIGATION UNDER THIS WARRANTY IS EXPRESSLY AND EXCLUSIVELY LIMITED to repairing or replacing such products that are returned within the warranty period with shipping charges prepaid and which will be disclosed as defective upon examination by Danray Products LLC. This warranty does not apply to any product that has been subject to misuse, negligence, accident, restriction, or use not in accordance with Danray Products LLC's instructions or which has been altered or repaired by persons other than authorized agents or employees of Danray Products LLC. Danray Products LLC's warranty for any component part is expressly limited to that of the manufacturer of the component part.

Disclaimer

The foregoing warranty is made in lieu of all other warranties, expressed or implied, and of all other liabilities and obligations on the part of Danray Products LLC, including any liability for negligence, strict liability, or otherwise, and any implied warranty of merchantability or fitness for a particular purpose is expressly disclaimed.

Limitation of Liability

Under no circumstances, including any claim of negligence, strict liability, or otherwise, will Danray Products LLC be liable for any incidental or consequential damages, or any loss or damage resulting from a defect in a product of Danray Products LLC.



DANRAY Products LLC

MACHINE SAFEGUARDS AND ACCESSORIES

973 Featherstone Road, Unit 115, Rockford, Illinois 61107-5908
Toll-Free 1.866.482.6807 / Phone 815.262.6667 / Fax 815.282.5186
www.danrayproducts.com / sales@danrayproducts.com

